

Model TQ2 Axial Torsion Force Transducer

- Measures force and torque
- Tension & compression – CW & CCW Torque
- Less than 2% crosstalk
- Excellent thermal compensation

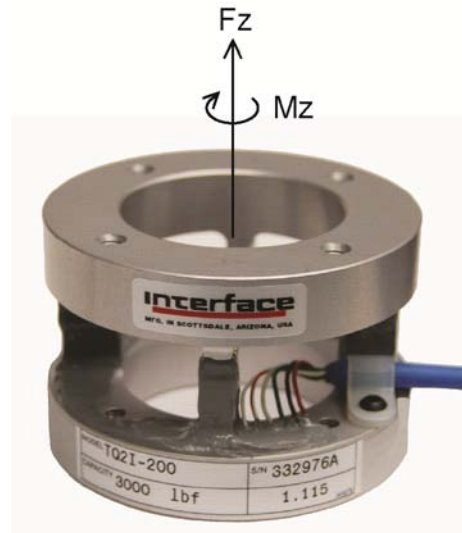

DIMENSIONS

See Drawing	CAPACITY
	lbf / inch-lb
	3000 / 200
(1)	2.00
(2)	2.99
(3)	1.772
(4)	0.55
(5)	M5 x 0.8 – 0.43 Deep – 8 Places
(6)	Label

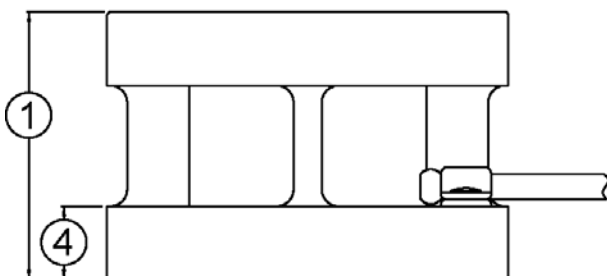
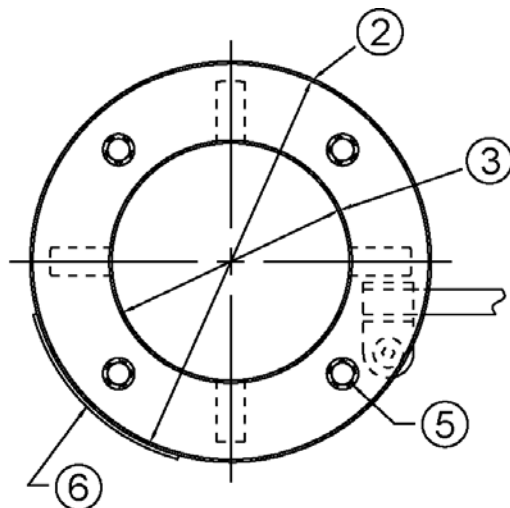

SPECIFICATIONS

ACCURACY – (MAX ERROR)	Axial Bridge A	Torsion Bridge B
Nonlinearity-% FS	±0.50	±0.25
Hysteresis-% FS	±0.50	±0.25
Nonrepeatability-% RO	±0.02	±0.05
Creep, in 20 min-%	±0.05	±0.05
TEMPERATURE		
Compensated Range-°F	15 to 115	15 to 115
Compensated Range-°C	-10 to 45	-10 to 45
Operating Range-°F	-65 to 200	-65 to 200
Operating Range-°C	-55 to 90	-55 to 90
Effect on Output-%/100F°-MAX	±0.02	±0.02
Effect on Zero-% RO/100F°-MAX	±0.15	±0.15
ELECTRICAL		
Rated Output-mV/V (Nominal)	1.0	0.7
Zero Balance-% RO	±2.0	±2.0
Input Resistance-Ohms	700±7	700±7
Output Resistance-Ohms	700±7	700±7
Excitation Voltage-MAX	20 VDC	20 VDC
MECHANICAL		
Calibration	T & C	CW & CCW
Safe Overload-% CAP	±200	±200