

2200 CALIBRATION COLUMN LOAD CELL (U.S. & METRIC)

FEATURES & BENEFITS

- Capacities from 100K to 200K lbf (445 to 890 kN)
- Performance to <0.10%FS
- ASTM E74 calibration
- Quadruple the gages of standard column cell
- Lightweight
- Compact

SPECIFICATIONS

ACCURACY – (MAX ERROR)		
Nonlinearity – %FS		±0.10
Hysteresis – %FS		±0.05
Nonrepeatability – %RO		±0.05
Creep, in 20 min – %		±0.05
TEMPERATURE		
Compensated Range	°F	+15 to +115
	°C	-9.4 to +46.1
Operating Range	°F	-30 to +175
	°C	-34.4 to +79.4
Effect on Zero – %RO / deg	°F	0.003
Effect on Output – % / deg	°F	0.003
ELECTRICAL		
Rated Output – mV/V (Nominal)		2.0 ± 0.20
Excitation – VAC / VDC – Nominal		10
Excitation – VAC / VDC MAX		15
Bridge Resistance – Ohm (Nominal)		350
Zero Balance – %RO		±1.0
Insulation Resistance – Megohm		> 5000
MECHANICAL		
Safe Overload – %CAP		150
Weight	lbs	35, 45
	kg	16, 20
Material		Stainless steel

OPTIONS

- Compression-only available (Ask factory for specifications and dimensions)
- Multiple bridge
- Standardized output
- Special thread size

ACCESSORIES

- Mating connector
- Cable assembly

International System of Units (SI) dimensions and capacities are provided for conversion only. Standard products have U.S. capacities and dimensions. SI capacities available upon special request and at an additional cost.

STANDARD CONFIGURATION



Model 2200 (Shown)

SIDE VIEW

TOP VIEW

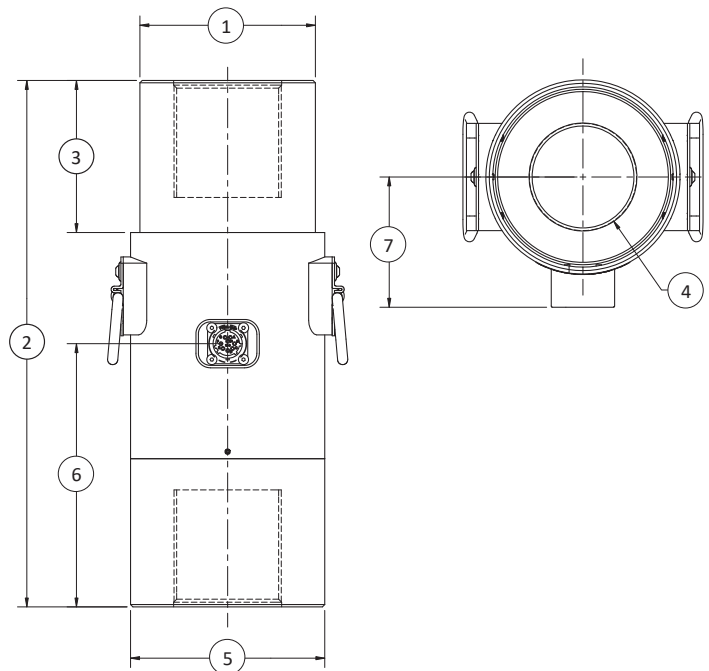

DIMENSIONS

See Drawing	MODEL			
	2230		2240	
	CAPACITY			
	U.S. (lbf)	Metric (kN)	U.S. (lbf)	Metric (kN)
	100K	445	200K	890
	in	mm	in	mm
(1)	3.0	76.2	4.5	114
(2)	10.1	257	13.5	343
(3)	2.75	70.0	3.9	99
(4)	1¼-12 UN 3B		2¼-8 UN 3B	
(5)	3.5	88.9	4.98	126.5
(6)	5.05	128.3	6.75	171.5
(7)	2.59	65.8	3.34	84.8