

Uniaxial MEMS Capacitive Accelerometer

Uniaxial

MEMS Capacitive

Measurement Range 3511LN: ± 2 to ± 400 g

Measurement Range 3521MF: ± 2 to ± 200 g

Noise Density 3511LN: 7 to 400 $\mu\text{g}/\sqrt{\text{Hz}}$

Noise Density 3521MF: 10 to 680 $\mu\text{g}/\sqrt{\text{Hz}}$

Frequency Range ($\pm 5\%$) 3511LN: DC to 1000 Hz

Frequency Range ($\pm 5\%$) 3521MF: : DC to 1500 Hz

Aluminum Housing



MEMS Capacitive Accelerometer

The key components in capacitive accelerometers are high-quality micro-electro-mechanical systems (MEMS) that feature excellent long-term stability and reliability. This technology enables the measurement of static (DC) and constant accelerations, which can be used to calculate the velocity and displacement of moving objects. Depending on the design of the spring-mass-damping system, however, it is also possible to detect dynamic (AC) accelerations with amplitudes up to ± 400 g and within a frequency response range of up to 1.5 kHz ($\pm 5\%$) or 7 kHz (± 3 dB). Other advantages of capacitive accelerometers are their outstanding temperature stability, excellent response behavior and achievable resolution.

Description

The accelerometers type ASC 3511|3521 are based on proven MEMS technology and capacitive operating principle. The integrated electronic circuitry enables a differential analog voltage output (LN: ± 4 V, MF: $\pm 2,7$ V) and wide power supply voltage (5 to 40 VDC). The LN (Low Noise) version provides an outstanding noise performance from 7 to 400 $\mu\text{g}/\sqrt{\text{Hz}}$, while the MF Version provides a wide frequency response range of 0 Hz to 7 kHz at ± 3 dB.

The housing design is extremely robust with a shock resistance up to 6000 g.

The sensors feature a lightweight, reliable aluminum housing with protection class IP65 and an integrated cable with configurable length and connectors.

The compact design of uniaxial 3511LN/3521MF enables numerous possible applications, such as shock and vibration tests regarding operational stability of HV batteries.

Features

- Very Low Noise Differential Voltage Output
- DC Response, Gas damped
- High Shock Resistance
- Excellent Offset and Scale Factor Stability

Options

- Customized Cable Length
- Customized Connector
- TEDS Module

Applications

- Operational Stability Tests
- Test Bench Applications
- E-Mobility, HV Batteries

More applications in several markets are figured out on our website www.pm-instrumentation.com

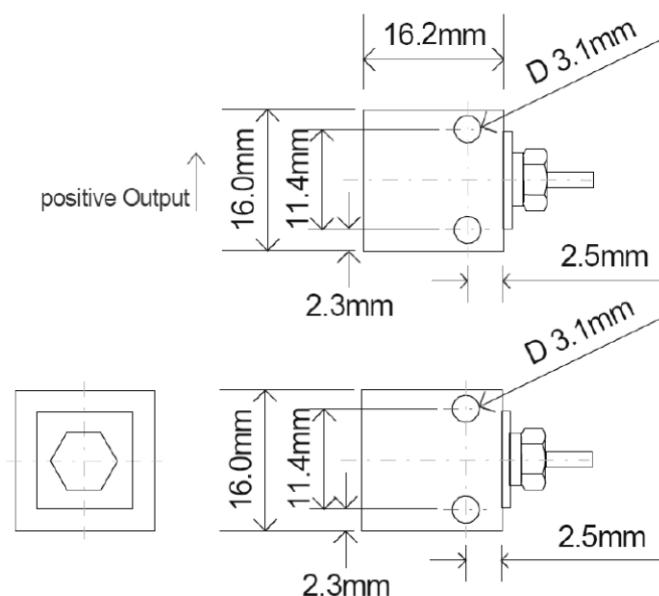

Typical Specification

Dynamic

Measurement Range	g	±2	±5	±10	±25	±50	±100	±200	±400
Scale Factor (sensitivity)	mV/g	2000	800	400	160	80	40	20	10
Noise Density	µg/√Hz	7	12	18	25	50	100	200	400
Specified Frequency Response Range (±5 %)	Hz	0 to 100	0 to 100	0 to 300	0 to 500	0 to 650	0 to 650	0 to 1000	0 to 1000
Frequency Response Range (±3 dB)	Hz	0 to 525	0 to 800	0 to 1100	0 to 1750	0 to 2100	0 to 3000	0 to 3600	0 to 4200
Amplitude Non-Linearity	% FSO	<0.15 (typ) <0.5 (max)							
Transverse Sensitivity	%	<2 (typ) <3 (max)							

Electrical

Power Supply Voltage	V	6 to 40							
Operating Current Consumption	mA	<10							
Offset (bias)	mV	±80	±80	±40	±40	±40	±40	±40	±40
Broadband Noise (over specified frequency range ±5 %)	µV	140	95	120	90	10	100	125	125
Output Impedance	Ω	90							
Isolation		Case isolated							

Environmental

Temperature Coefficient of the Scale Factor (max)	ppm/K	±200							
Temperature Coefficient of the Offset (max)	mg/K	±0.8	±2	±4	±10	±20	±40	±80	±160
Operating Temperature Range	°C	-40 to +100							
Storage Temperature Range	°C	-40 to +100							
Shock Limit (max peak)	g	2000	2000	5000	5000	5000	5000	5000	5000
Protection Class		IP65							

Physical

Sensing Element		MEMS Capacitive							
Case Material		Anodized Aluminum							
Connector at Cable End		Optional							
Mounting		Adhesive							
Weight (without cable)	gram	22							
Cable		13 gram per meter AWG 30 Polyurethane (PUR) Diameter 3.1 mm							

Sensor Calibration

Factory Calibration (supplied with the sensor)

Part Number									
Measurement Range (sensor)	g	±2	±5	±10	±25	±50	±100	±200	±400
Applied Frequency (min)	Hz	1	10	10	10	10	10	10	10
Applied Frequency (max)	Hz	100	100	300	500	650	650	1000	1000
Input Amplitude	m/s ²	5	5	50	100	200	200	200	200
Reference Frequency for Determination of Scale Factor	Hz	16	80	80	80	80	80	80	80

Calibration according DIN ISO 17025 (order separately)

Part Number									
Measurement Range (sensor)	g	±2	±5	±10	±25	±50	±100	±200	±400
Applied Frequency (min)	Hz	0.5	10	10	10	10	10	10	10
Applied Frequency (max)	Hz	150	150	500	800	1600	1600	2000	2000
Input Amplitude	m/s ²	5	5	50	100	200	200	200	200
Reference Frequency for Determination of Scale Factor	Hz	16	80	80	80	80	80	80	80

Remarks:

- The conversion factor 1 g corresponds to 9.80665 m/s².
- If any other calibration procedure is required, don't hesitate to contact us. Our services include both factory calibration and calibration in accordance with DAkkS guidelines.
- Furthermore, sensors have to be calibrated regularly to ensure accurate and precise results. On request we will be glad to remind you of the next scheduled calibration of your sensors.

Cable Code / Pin Configuration (4 Wire System)

	Pin	Color Code	Description
1	Supply +	Red	Power supply voltage +6 to +40 VDC
2	Supply -	Black	Power GND
3	Signal +	Green	Positive, analog output voltage signal for differential mode
4	Signal -	White	Negative, analog output voltage signal for differential mode

Typical Specification

Dynamic

Measurement Range	g	±2	±5	±10	±30	±50	±100	±200
Scale Factor (sensitivity)	mV/g	1350	540	270	90	54	27	13.5
Noise Density	µg/√Hz	10	20	35	100	170	340	680
Specified Frequency Response Range (±5 %)	Hz	0 to 100	0 to 700	0 to 1000	0 to 1500	0 to 1500	0 to 1500	0 to 1500
Frequency Response Range (±3 dB)	Hz	0 to 1150	0 to 1900	0 to 3200	0 to 4000	0 to 4500	0 to 5000	0 to 7000
Amplitude Non-Linearity	% FSO	<0.1 (typ) <0.3 (max)						
Transverse Sensitivity	%	<1						

Electrical

Power Supply Voltage	V	5 to 40						
Operating Current Consumption	mA	<10						
Offset (bias)	mV	±10						
Broadband Noise (over specified frequency range ±5 %)	µV	250	310	410	440	475	490	460
Resistive Load	kΩ	1000						
Isolation		Case Isolated						

Environmental

Temperature Coefficient of the Scale Factor	ppm/K	120 (typ) 20 to 220 (max)						
Temperature Coefficient of the Offset (max)	mg/K	±0.2	±0.5	±1	±3	±5	±10	±20
Operating Temperature Range	°C	-40 to +100						
Storage Temperature Range	°C	-40 to +100						
Shock Limit (0.1 ms, half-sine)	g	6000						
Protection Class		IP65						

Physical

Sensing Element		MEMS Capacitive						
Case Material		Anodized Aluminum						
Connector at Cable End		Optional						
Mounting		Adhesive Screw Holes						
Weight (without cable)	gram	22						
Cable		13 gram per meter AWG 30 Polyurethane (PUR) Diameter 3.1 mm						

Sensor Calibration

Factory Calibration (supplied with the sensor)

Part Number		#16722	#16754	#16756	#16758	#16760	#16762	#16764
Measurement Range (sensor)	g	±2	±5	±10	±30	±50	±100	±200
Applied Frequency (min)	Hz	1	10	10	10	10	10	10
Applied Frequency (max)	Hz	100	7000	1400	1600	1800	1800	1800
Input Amplitude	m/s ²	5	5	50	100	200	200	200
Reference Frequency for Determination of Scale Factor	Hz	16	80	80	80	80	80	80

Calibration according DIN ISO 17025 (order separately)

Part Number		#16738	#16766	#16768	#16770	#16772	#16774	#16776
Measurement Range (sensor)	g	±2	±5	±10	±30	±50	±100	±200
Applied Frequency (min)	Hz	0.5	10	10	10	10	10	10
Applied Frequency (max)	Hz	150	1200	2000	2300	2500	2500	2500
Input Amplitude	m/s ²	5	5	50	100	200	200	200
Reference Frequency for Determination of Scale Factor	Hz	16	80	80	80	80	80	80

Remarks:

- The conversion factor 1 g corresponds to 9.80665 m/s².
- If any other calibration procedure is required, don't hesitate to contact us. Our services include both factory calibration and calibration in accordance with DAkkS guidelines.
- Furthermore, sensors have to be calibrated regularly to ensure accurate and precise results. On request we will be glad to remind you of the next scheduled calibration of your sensors.

Cable Code / Pin Configuration (4 Wire System)

	Pin	Color Code	Description
1	Supply +	Red	Power supply voltage +5 to +40 VDC
2	Supply -	Black	Power GND
3	Signal +	Green	Positive, analog output voltage signal for differential mode
4	Signal -	White	Negative, analog output voltage signal for differential mode

Ordering Information

Series	Model	- Range [g]	- Cable Length [m]	Connector & Pinout
ASC 35	11LN	002	6	A
	21MF	005		
		010		
		025		
		050		
		100		
		200		
		400		

Example: **ASC 3511LN-002-6A**
ASC 3521MF-010-10A

Ordering information are based on standard configurations. All customized versions regarding connector and/or pinout will lead to a corresponding product match code:

- Standard length of the integrated cable is 6 meters. However, different customized cable lengths are possible on request.
- Standard version has no connector at the cable end which is identified by "A" in the product match code. However, it is possible to assemble almost all connector types during production.

Safety Precaution for Installing and Operating

This data sheet is a part of the product. Read the data sheet carefully before using the product and keep it available for future operation. Handling, electrical connections, mounting or any other work performed at the sensor must be carried out by authorized experts only. Appropriate safety precautions must be taken to exclude any risk of personal injury and damage to operating equipment as a result of a sensor malfunction.

Handling

The sensor is packaged in a reliable housing to protect the sensing elements and integrated electronic components from the ambient environment. However, poor handling of the product can lead to damages that may not be visible and cause electrical failure or reliability issues. Handle the component with caution:

- Avoid shocks and impacts on the housing, such as dropping the sensor on hard surface
- Never move the sensor by pulling the cable
- Make sure that the sensor is used within the specified environmental conditions
- Transport and store the sensor in its original or similar packaging
- The sensor should be mounted on a stable flat surface with all screws tightened or other mounting options
- Avoid any deformation during mounting the sensor
- Mounting tolerances may have an influence on the measured result

Electrical

ASC's inertial sensors are working with many established data acquisition systems. However, make sure that a proper DAQ is used, for the corresponding operation principle of the sensor. Furthermore, suitable precautions shall be employed during all phases of shipment, handling and operating:

- Active sensor pins are susceptible to damage due to electrostatic discharge (ESD)
- Make sure that the sensor is used within the specified electrical conditions
- Check all electrical connections prior to initial setup of the sensor
- Completely shield the sensor and connecting cable
- Do not perform any electrical modifications at the sensor
- Do not perform any adaptations on the wiring or connectors while the device under power
- Never plug or unplug the electrical connection while the sensor is under power
- When a certain pin is not used during operation, make sure that the pin is insulated

Quality

- We have a quality management system according to ISO 9001:2015.
- The Deutsche Akkreditierungsstelle GmbH (DAkkS) has awarded to our calibration laboratory the DIN EN ISO/IEC 17025:2018 accreditation for calibrations and has confirmed our competence to perform calibrations in the field of mechanical acceleration measurements. The registration number of the certificate is **D-K-18110-01-00**.
- All ASC products are **CE**-compliant.