

## MEMS Capacitive Accelerometer

### ASC 4411LN | ASC 4415LN

Uniaxial

MEMS Capacitive

Measurement Range:  $\pm 2$  to  $\pm 400$  g

Noise Density: 7 to 400  $\mu\text{g}/\sqrt{\text{Hz}}$

Frequency Range ( $\pm 5\%$ ): DC to 1000 Hz

Aluminum or Stainless-Steel Housing

**Made in Germany**



CE

### MEMS Capacitive Accelerometer

The key components in capacitive accelerometers are high-quality micro-electro-mechanical systems (MEMS) that feature excellent long-term stability and reliability. This technology enables the measurement of static (DC) and constant accelerations, which can be used to calculate the velocity and displacement of moving objects. Depending on the design of the spring-mass-damping system, however, it is also possible to detect dynamic (AC) accelerations with amplitudes up to  $\pm 400$  g and within a frequency response range of up to 1 kHz ( $\pm 5\%$ ) or 4.2 kHz ( $\pm 3$  dB). Other advantages of capacitive accelerometers are their outstanding temperature stability, excellent response behavior and achievable resolution.

#### Description

The accelerometers of type ASC 4411LN and ASC 4415LN are based on proven MEMS technology and capacitive operating principle. The integrated electronic circuitry enables a differential analog voltage output ( $\pm 4$  V FSO) and flexible power supply voltage from 6 to 40 VDC. The LN (Low Noise) accelerometers from ASC provide an outstanding noise performance from 7 to 400  $\mu\text{g}/\sqrt{\text{Hz}}$  which is essential for demanding measurements of smallest frequencies and amplitudes.

The sensor ASC 4411LN features a lightweight aluminum housing and the sensor ASC 4415LN provides a robust stainless-steel housing, both with protection class IP67 and an integrated cable with configurable length and connectors.

The uniaxial accelerometers feature a flat design that allows quick and easy mounting, a basic requirement in NVH (noise, vibration, harshness) and test bench applications or for evaluating driving comfort and vehicle dynamics.

#### Features

- Very Low Noise Differential Voltage Output
- DC Response, Gas damped
- High Shock Resistance
- Excellent Offset and Scale Factor Stability

#### Options

- Customized Cable Length
- Customized Connector
- TEDS Module

#### Applications

- Noise, Vibration, Harshness
- Driving and Ride Comfort Tests
- Vehicle and Running Dynamics

More applications in several markets are figured out on our web page [www.asc-sensors.de](http://www.asc-sensors.de)

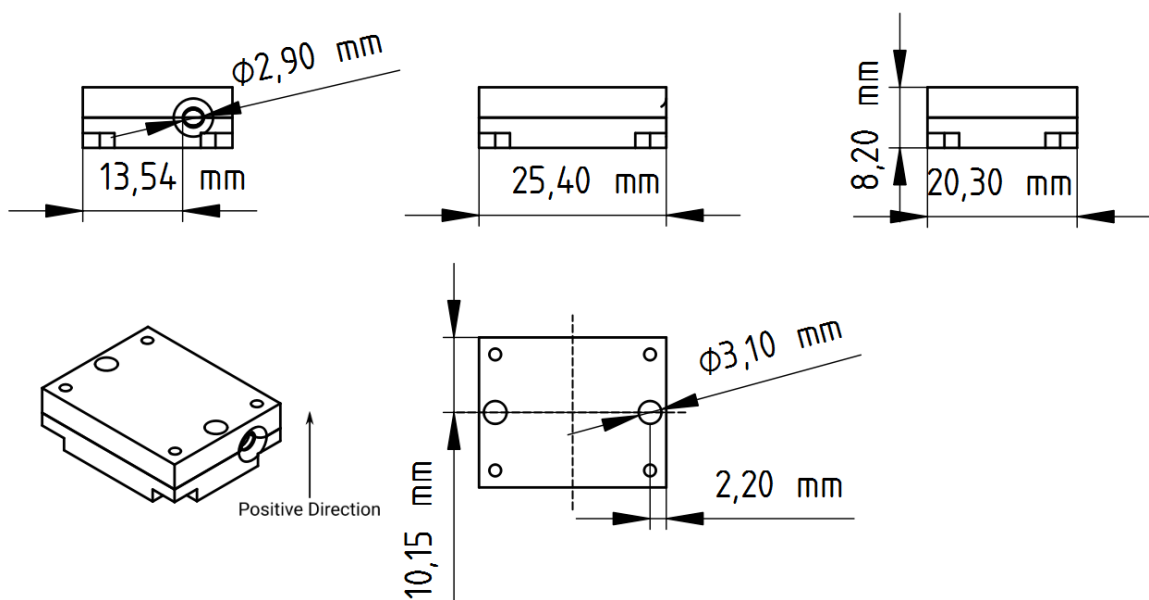

# ASC 4411LN | ASC 4415LN

## MEMS Capacitive Accelerometer



### Typical Specification

#### Dynamic

Measurement Range	g	±2	±5	±10	±25	±50	±100	±200	±400
Scale Factor (sensitivity)	mV/g	2000	800	400	160	80	40	20	10
Noise Density	µg/√Hz	7	12	18	25	50	100	200	400
Min. Frequency Response Range (±5 %)	Hz	0 to 100	0 to 100	0 to 300	0 to 500	0 to 650	0 to 650	0 to 1000	0 to 1000
Max. Frequency Response Range (±3 dB)	Hz	0 to 525	0 to 800	0 to 1100	0 to 1750	0 to 2100	0 to 3000	0 to 3600	0 to 4200
Amplitude Non-Linearity	% FSO	<0.15 (typ)   <0.5 (max)							
Transverse Sensitivity	%	<2 (typ)   <3 (max)							

#### Electrical

Power Supply Voltage	V	6 to 40							
Operating Current Consumption	mA	<10							
Offset (bias)	mV	±80	±80	±40	±40	±40	±40	±40	±40
Broadband Noise (over min frequency range ±5 %)	µV	140	95	125	90	100	100	125	125
Output Impedance	Ω	90							
Isolation	Integrated electronic circuitry is isolated from the sensor housing   Sensor housing and cable shielding are internally connected								

#### Environmental

Temperature Coefficient of the Scale Factor (max)	ppm/K	±200							
Temperature Coefficient of the Offset (max)	mg/K	±0.8	±2	±4	±10	±20	±40	±80	±160
Operating Temperature Range	°C	-40 to +125							
Storage Temperature Range	°C	-40 to +125							
Shock Limit (max peak)	g	2000	2000	5000	5000	5000	5000	5000	5000
Protection Class	IP67								

#### Physical

Sensing Element	MEMS Capacitive								
Case Material	ASC 4411LN: Anodized Aluminum ASC 4415LN: Stainless-Steel								
Connector at Cable End	Optional								
Mounting	Adhesive   Screw Holes								
Weight (without cable)	gram	ASC 4411LN: 10 ASC 4415LN: 22							
Cable	13 gram per meter   AWG 30   Polyurethane (PUR)   Diameter 3.1 mm								

**Sensor Calibration**

**Factory Calibration (supplied with the sensor)**

Part Number		#12054	#12054	#14514	#14523	#14527	#14527	#14531	#14531
Measurement Range (sensor)	g	±2	±5	±10	±25	±50	±100	±200	±400
Applied Frequency (min)	Hz	1	1	10	10	10	10	10	10
Applied Frequency (max)	Hz	100	100	300	500	650	650	1000	1000
Input Amplitude	m/s <sup>2</sup>	5	5	50	100	200	200	200	200
Reference Frequency for Determination of Scale Factor	Hz	16	16	80	80	80	80	80	80

**Calibration according DIN ISO 17025 (order separately)**

Part Number		#14512	#14512	#14516	#14525	#14529	#14529	#14533	#14533
Measurement Range (sensor)	g	±2	±5	±10	±25	±50	±100	±200	±400
Applied Frequency (min)	Hz	0.5	0.5	10	10	10	10	10	10
Applied Frequency (max)	Hz	150	150	500	800	1600	1600	2000	2000
Input Amplitude	m/s <sup>2</sup>	5	5	50	100	200	200	200	200
Reference Frequency for Determination of Scale Factor	Hz	16	16	80	80	80	80	80	80

Remarks:

- The conversion factor 1 g corresponds to 9.80665 m/s<sup>2</sup>.
- If any other calibration procedure is required, don't hesitate to contact us. Our services include both factory calibration and calibration in accordance with DAkkS guidelines.
- Furthermore, sensors have to be calibrated regularly to ensure accurate and precise results. On request we will be glad to remind you of the next scheduled calibration of your sensors.

**Cable Code / Pin Configuration (4 Wire System)**

	Pin	Color Code	Description
1	Supply +	Red	Power supply voltage +6 to +40 VDC
2	Supply -	Black	Power GND
3	Signal +	Green	Positive, analog output voltage signal for differential mode
4	Signal -	White	Negative, analog output voltage signal for differential mode

Cable shielding is provided as a tinned-copper braiding which is also internally connected to the sensor housing

# ASC 4411LN | ASC 4415LN

## MEMS Capacitive Accelerometer



### Ordering Information

Series	Model	- Range [g]	- Cable Length [m]	Connector & Pinout
ASC 44	11LN (Aluminum)	002	6	A
	15LN (Stainless-steel)	005		
		010		
		025		
		050		
		100		
		200		
		400		

*Example:*

**ASC 4411LN-002-6A**

Ordering information are based on standard configurations. All customized versions regarding connector and/or pinout will lead to a corresponding product match code:

- Standard length of the integrated cable is 6 meters. However, different customized cable lengths are possible on request.
- Standard version has no connector at the cable end which is identified by "A" in the product match code. However, it is possible to assemble almost all connector types during production.

## MEMS Capacitive Accelerometer

### Safety Precaution for Installing and Operating

This data sheet is a part of the product. Read the data sheet carefully before using the product and keep it available for future operation. Handling, electrical connections, mounting or any other work performed at the sensor must be carried out by authorized experts only. Appropriate safety precautions must be taken to exclude any risk of personal injury and damage to operating equipment as a result of a sensor malfunction.

### Handling

The sensor is packaged in a reliable housing to protect the sensing elements and integrated electronic components from the ambient environment. However, poor handling of the product can lead to damages that may not be visible and cause electrical failure or reliability issues. Handle the component with caution:

- Avoid shocks and impacts on the housing, such as dropping the sensor on hard surface
- Never move the sensor by pulling the cable
- Make sure that the sensor is used within the specified environmental conditions
- Transport and store the sensor in its original or similar packaging
- The sensor should be mounted on a stable flat surface with all screws tightened or other mounting options
- When adhesives are used to mount the sensors, please select the corresponding products according to permanent or removable mounting, ambient temperature range as well as quality of the mounting surface
- Avoid any deformation during mounting the sensor
- Mounting tolerances may have an influence on the measured result

### Electrical

ASC's inertial sensors are working with many established data acquisition systems. However, make sure that a proper DAQ is used, for the corresponding operation principle of the sensor. Furthermore, suitable precautions shall be employed during all phases of shipment, handling and operating:

- Active sensor pins are susceptible to damage due to electrostatic discharge (ESD)
- Make sure that the sensor is used within the specified electrical conditions
- Check all electrical connections prior to initial setup of the sensor
- An incorrect wiring of the signal or power supply connections will lead to damages of the sensor
- Completely shield the sensor and connecting cable according to your application
- Do not perform any electrical modifications at the sensor
- Do not perform any adaptations on the wiring or connectors while the device under power
- Never plug or unplug the electrical connection while the sensor is under power
- When a certain pin is not used during operation, make sure that the pin is insulated

### Quality

- We have a quality management system according to **ISO 9001:2015**.
- The Deutsche Akkreditierungsstelle GmbH (DAkkS) has awarded to our calibration laboratory the **DIN EN ISO/IEC 17025:2018** accreditation for calibrations and has confirmed our competence to perform calibrations in the field of mechanical acceleration measurements. The registration number of the certificate is **D-K-18110-01-00**.
- The sensors described in the data sheet are **CE**-compliant.

Made in Germany



analyzing



monitoring



testing



measuring