

## MEMS Capacitive Accelerometer

### ASC EQ-x211 | ASC EQ-x215

Uniaxial, Biaxial, Triaxial  
 MEMS Capacitive  
 Measurement Range:  $\pm 3$  and  $\pm 5$  g  
 Noise Density:  $< 1.2 \mu\text{g}/\sqrt{\text{Hz}}$   
 Frequency Range ( $\pm 3$  dB): DC to 700 Hz  
 Aluminum or Stainless-Steel Housing  
**Made in Germany**



### MEMS Capacitive Accelerometer

The key components in capacitive accelerometers are high-quality micro-electro-mechanical systems (MEMS) that feature excellent long-term stability and reliability. This technology enables the measurement of static (DC) and constant accelerations, which can be used to calculate the velocity and displacement of moving objects. Depending on the design of the spring-mass-damping system, however, it is also possible to detect dynamic (AC) accelerations with a bandwidth of up to 700 Hz ( $\pm 3$  dB) and amplitudes up to  $\pm 5$  g. Other advantages of capacitive accelerometers are their outstanding temperature stability, excellent response behavior and achievable resolution.

### Description

Accelerometers of ASC EQ-series are based on proven MEMS technology and capacitive operating principle. The integrated electronic circuitry enables a differential analog voltage output ( $\pm 2.7$  V FSO) and flexible power supply voltage from 5 to 40 VDC. The sensors of the ASC EQ series feature an ultra-low noise level and achieve a resolution of less than  $1 \mu\text{g}$ . They therefore fulfill the requirements of motion class B of seismic measurements.

The sensors ASC EQ-x211 feature a lightweight aluminum housing and the sensors ASC EQ-x215 provide a robust stainless-steel housing, both with protection class IP65 and with detachable cable as well as configurable length and connectors. The accelerometers are available in uniaxial, biaxial and triaxial configuration.

Safety-critical components of buildings must be monitored continuously. This is especially the case in power plants or tunnels, whose structures that are affected by tectonic processes. A basic requirement here is the use of seismic sensors that reliably detect the smallest amplitudes of vibrations.

### Features

- Ultra-low Noise Differential Voltage Output
- DC Response, Gas-damped
- High Shock Resistance
- Excellent Bias and Scale Factor Stability
- Built-in Self-Test Option
- Temperature Output

### Options

- Customized Cable Length
- Customized Connector
- Selectable Axes Configuration
- Protection Class IP68 using an integrated Cable and PG Gland

### Applications

- Structural Health Monitoring
- Seismic Sensing
- Noise Measurements

More applications in several markets are figured out on our web page [www.asc-sensors.de](http://www.asc-sensors.de)

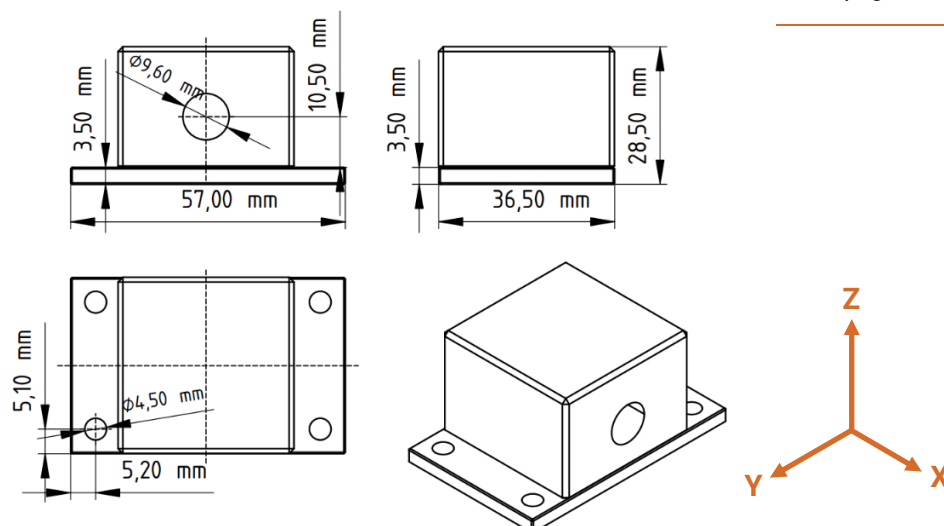

**Typical Specification**

**Dynamic**

Measurement Range	g	±3	±5
Scale Factor (sensitivity)	mV/g	900	540
Noise Density	µg/√Hz	0.7	1.2
Frequency Response Range (±3 dB)	Hz	0 to 550	0 to 700
Amplitude Non-Linearity	% FSO	<0.3 (typ)   <1 (max)	
Transverse Sensitivity	%	<1	

**Electrical**

Power Supply Voltage	V	5 to 40	
Operating Current Consumption	mA	27 ±5 (per axis)	
Offset (bias)	mV	±10	
Broadband Noise (over frequency range 0.1 to 100 Hz)	µV	<10	
Isolation	Integrated electronic circuitry is isolated from the sensor housing   Sensor housing and Comtronic chassis are connected to apply the cable shielding		

**Self-Test Option**

Duty Cycle	%	50	
Emulated Output Amplitude	g	0.25	0.5
Expected Frequency	Hz	19 ±5	

**Temperature Sensor**

Output Voltage at 20 °C	V	1.22 ±0.01	
Scale Factor	mV/K	-4.35 ±0.05	

**Environmental**

Temperature Coefficient of Scale Factor	ppm/K	120 (typ)   20 to 220 (max)	
Temperature Coefficient of the Offset	mg/K	0.3 (max)	0.5 (max)
Operating Temperature Range	°C	-40 to +85	
Storage Temperature Range	°C	-40 to +100	
Shock Limit (0.15 ms, single shocks)	g	1500	
Protection Class	IP65 (IP68 hermetical sealing on request)		

**Physical**

Sensing Element	MEMS capacitive		
Case Material	ASC EQ-x211: Anodized Aluminum   ASC EQ-x215: Stainless-Steel		
Connector	12-pin Comtronic (male)		
Mounting	Adhesive   Screw Holes		
Weight (without cable)	gram	ASC EQ-x211: 75   ASC EQ-x215: 190	
Cable	30 gram per meter   AWG 30   Polyurethane (PUR)   Diameter 4.5 mm		

**Sensor Calibration**

**Factory Calibration (supplied with the sensor)**

Part Number		#12054		#12054		#14496	
Number of Sensitive Directions		Uniaxial		Biaxial		Triaxial	
Measurement Range (sensor)	g	±3	±5	±3	±5	±3	±5
Applied Frequency Range	Hz			1 to 100			
Input Amplitude	m/s <sup>2</sup>			5			
Reference Frequency for Determination of Scale Factor	Hz			16			

**Calibration according DIN ISO 17025 (order separately)**

Part Number		#14512		#14512		#14513	
Number of Sensitive Directions		Uniaxial		Biaxial		Triaxial	
Measurement Range (sensor)	g	±3	±5	±3	±5	±3	±5
Applied Frequency Range	Hz			0.5 to 150			
Input Amplitude	m/s <sup>2</sup>			5			
Reference Frequency for Determination of Scale Factor	Hz			16			

Please note: The conversion factor 1 g corresponds to 9.80665 m/s<sup>2</sup>. If any other calibration procedure is required, don't hesitate to contact us. Furthermore, sensors have to be calibrated regularly to ensure accurate and precise results. Our services include both factory calibration and calibration in accordance with DAkkS guidelines. On request we will be glad to remind you of the next scheduled calibration of your sensors.

**Cable Configuration for detachable Connector Cable ASC AK-EQ (see accessories)**

**6 Wire System - 6L (Uniaxial)**

Common power supply for all axes, no cable switch



**9 Wire System - 9L (Biaxial)**

Common power supply for all axes, no cable switch



**12 Wire System - 12L (Triaxial)**

Common power supply for all axes, no cable switch



**9 Wire System - 9L2 (Biaxial)**

Common power supply for all axes, including cable switch

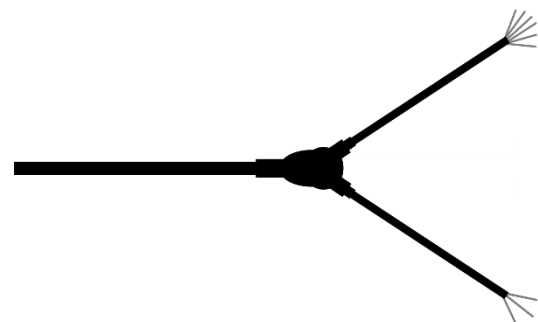

**12 Wire System - 12L3 (Triaxial)**

Common power supply for all axes, including cable switch

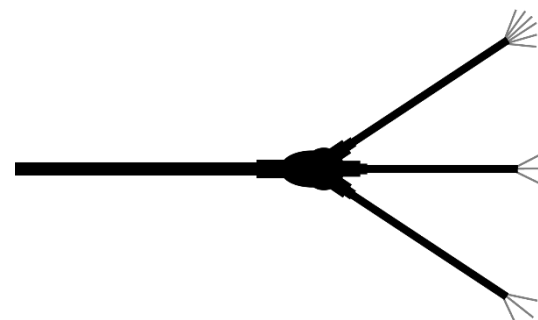

## MEMS Capacitive Accelerometer

### Detachable Connecting Cable Code / Pin Configuration (12 Wire System) including common Power Supply for all Axes

	12-Pin Sensor Connector (male)	Color Code ASC AK-EQ	Description
2	Supply +	Red	Power: supply voltage +5 to +40 VDC
1	Supply -	Black	Power: GND
9	Self-Test	Black/Grey	Self-Test: active high between 2.7 V to 3.3 V for all sensitive directions
11	Signal +	Green	Z-Axis: positive, analog output voltage signal for differential mode
12	Signal -	White	Z-Axis: negative, analog output voltage signal for differential mode
5	Temp	Black/Violet	Z-Axis: analog output voltage temperature sensor
8	Signal +	Green/Grey	Y-Axis: positive, analog output voltage signal for differential mode
10	Signal -	White/Grey	Y-Axis: negative, analog output voltage signal for differential mode
4	Temp	Red/Grey	Y-Axis: analog output voltage temperature sensor
6	Signal +	Green/Violet	X-Axis: positive, analog output voltage signal for differential mode
7	Signal -	White/Violet	X-Axis: negative, analog output voltage signal for differential mode
3	Temp	Red/Violet	X-Axis: analog output voltage temperature sensor

Shielding of the detachable connecting cable is provided as a tinned-copper braiding which is also connected to the Comtronic chassis to apply a corresponding shielding of the sensor housing

In the table above the cable code and pin configuration based on a 12 wire system (triaxial) is figured out. Referring to the ordering information there are different axes configurations available. That means the standard uniaxial version is not fixed to Z-axis but could be fabricated in Y or X configuration. Furthermore, the biaxial version is not fixed to YX but is also available in ZY or ZX configuration. However, the color code of the detachable connector cable ASC AK-EQ for the corresponding axis as well as the configuration of the 12-pin Comtronic connector of the sensor will be always the same for all possible sensor configurations. Please, contact us for further details and options.

### Self-Test Option

The accelerometers of ASC EQ-series are featuring a built-in self-test option for validation of the functionality of the sensor. This feature is available when pin "Self-Test" is active high between 2.7 V to 3.3 V. When activated, an electrostatic force is applied to the micro-mechanical structure leading to a deflection of the seismic mass that is similar to an input acceleration.

Because it is an alternating electrostatic force the self-test mode generates a square wave signal (duty cycle 50 %, frequency 19 Hz) that is measurable at the analog output voltage signal pins "Signal +" and "Signal -". However, the electrostatic force is always applied additional to any other input acceleration. Therefore, the measured values depend also on the position within the Gravity of Earth while the specified range of the emulated output voltage is similar.

The typical voltage output signal for a sensor of the ASC EQ-series with measurement range of ±5 g is shown in the following graphs.

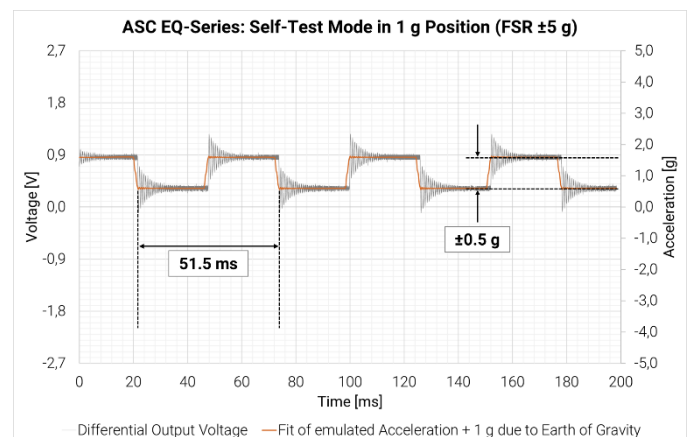
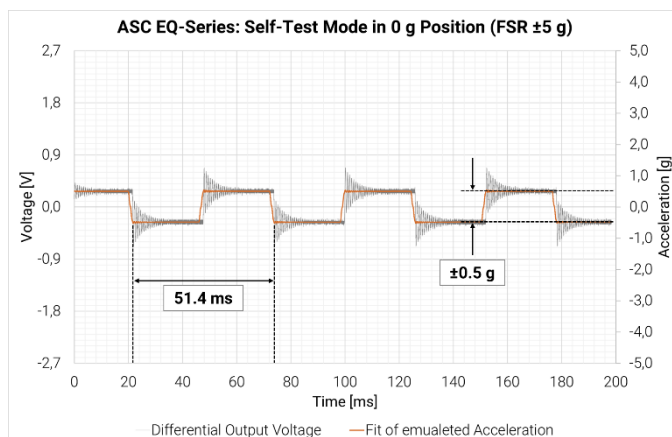

# ASC EQ-x211 | ASC EQ-x215

## MEMS Capacitive Accelerometer



### Ordering Information

Series	Sensitive Directions	Model	Housing Material	Range [g]	Axes Configuration
ASC EQ	1 (Uniaxial)	21	1 (Aluminum)	003	Z (Uniaxial, standard)
	2 (Biaxial)		5 (Stainless-Steel)	005	Y (Uniaxial)
	3 (Triaxial)				X (Uniaxial)
					YX (Biaxial, standard)
					ZY (Biaxial)
					ZX (Biaxial)

**Example:**

**ASC EQ-1211-003-Z**

### Accessories

Cable	ASC Sensor	Wires	Cable Length [m]	Connector & Pinout	Cable Configuration
ASC AK	EQ-1211-(Z, Y or X, corresponding to the axes selection)	12	6	open	6L (Uniaxial)
	EQ-2211-(YX, ZY or ZX, corresponding to the axes selection)				9L (Biaxial)
	EQ-3211				9L2 (Biaxial)
	EQ-1215				12L (Triaxial)
	EQ-2215				12L3 (Triaxial)
	EQ-3215				

**Example:**

**ASC AK-EQ-1211-Z 12/06/open-6L**

All types of ASC EQ-series are fabricated for operating with a detachable connector cable which is part of the product but needs to be ordered separately. For connecting the sensor housing, a 12-pin Comtronic connector (female) is used and already assembled. Furthermore, the cable features different options like configurable length, integrating a cable switch or connectors at the cable end including customized pin configuration. Please contact us for further information.

Ordering information are based on standard configurations. All customized versions regarding connector and/or pinout will lead to a corresponding product match code:

- Standard length of the detachable cable is 6 meters. However, different customized cable lengths are possible on request.
- Standard version has no connector at the cable end which is identified by "open" in the product match code. However, it is possible to assemble almost all connector types during production.

### Safety Precaution for Installing and Operating

This data sheet is a part of the product. Read the data sheet carefully before using the product and keep it available for future operation. Handling, electrical connections, mounting or any other work performed at the sensor must be carried out by authorized experts only. Appropriate safety precautions must be taken to exclude any risk of personal injury and damage to operating equipment as a result of a sensor malfunction.

### Handling

The sensor is packaged in a reliable housing to protect the sensing elements and integrated electronic components from the ambient environment. However, poor handling of the product can lead to damages that may not be visible and cause electrical failure or reliability issues. Handle the component with caution:

- Avoid shocks and impacts on the housing, such as dropping the sensor on hard surface
- Never move the sensor by pulling the cable
- Make sure that the sensor is used within the specified environmental conditions
- Transport and store the sensor in its original or similar packaging
- The sensor should be mounted on a stable flat surface with all screws tightened or other mounting options
- When adhesives are used to mount the sensors, please select the corresponding products according to permanent or removable mounting, ambient temperature range as well as quality of the mounting surface
- Avoid any deformation during mounting the sensor
- Mounting tolerances may have an influence on the measured result

### Electrical

ASC's inertial sensors are working with many established data acquisition systems. However, make sure that a proper DAQ is used, for the corresponding operation principle of the sensor. Furthermore, suitable precautions shall be employed during all phases of shipment, handling and operating:

- Active sensor pins are susceptible to damage due to electrostatic discharge (ESD)
- Make sure that the sensor is used within the specified electrical conditions
- Check all electrical connections prior to initial setup of the sensor
- An incorrect wiring of the signal or power supply connections will lead to damages of the sensor
- Completely shield the sensor and connecting cable according to your application
- Do not perform any electrical modifications at the sensor
- Do not perform any adaptations on the wiring or connectors while the device under power
- Never plug or unplug the electrical connection while the sensor is under power
- When a certain pin is not used during operation, make sure that the pin is insulated

### Quality

- We have a quality management system according to **ISO 9001:2015**.
- The Deutsche Akkreditierungsstelle GmbH (DAkkS) has awarded to our calibration laboratory the **DIN EN ISO/IEC 17025:2018** accreditation for calibrations and has confirmed our competence to perform calibrations in the field of mechanical acceleration measurements. The registration number of the certificate is **D-K-18110-01-00**.

Made in Germany



analyzing



monitoring



testing



measuring