

MEMS Capacitive Accelerometer for Railway Applications

ASC RAIL-x151LN

Uniaxial, Biaxial
 MEMS Capacitive
 Measurement Range: ± 2 to ± 400 g
 Noise Density: 7 to 400 $\mu\text{g}/\sqrt{\text{Hz}}$
 Frequency Range ($\pm 5\%$): DC to 1000 Hz
 Stainless-Steel Housing (IP68)

Made in Germany



MEMS Capacitive Accelerometer

The key components in capacitive accelerometers are high-quality micro-electro-mechanical systems (MEMS) that feature excellent long-term stability and reliability. This technology enables the measurement of static (DC) and constant accelerations, which can be used to calculate the velocity and displacement of moving objects. Depending on the design of the spring-mass-damping system, however, it is also possible to detect dynamic (AC) accelerations with amplitudes up to ± 400 g and within a frequency response range of up to 1 kHz ($\pm 5\%$) or 4.2 kHz (± 3 dB). Other advantages of capacitive accelerometers are their outstanding temperature stability, excellent response behavior and achievable resolution.

Description

The accelerometers of type ASC RAIL-x151LN are based on proven MEMS technology and capacitive operating principle. The integrated electronic circuitry enables a differential analog voltage output (± 4 V FSO) and flexible power supply voltage from 6 to 40 VDC. The LN (Low Noise) accelerometers from ASC provide an outstanding noise performance from 7 to 400 $\mu\text{g}/\sqrt{\text{Hz}}$ which is essential for demanding measurements of smallest frequencies and amplitudes.

The sensors feature a robust and reliable stainless-steel housing (V2A material number 1.4301) with protection class IP68 and an integrated cable with configurable length and connectors.

Through the rigorous testing and documentation according to EN 50155 it is significantly easier for railway operators to configure and implement individual inertial sensor solutions on their rolling stock. They can rely on a proven set of stable precision sensors ready for installation, which meet the required norms and significantly reduce individual documentation requirements on the part of the operator.

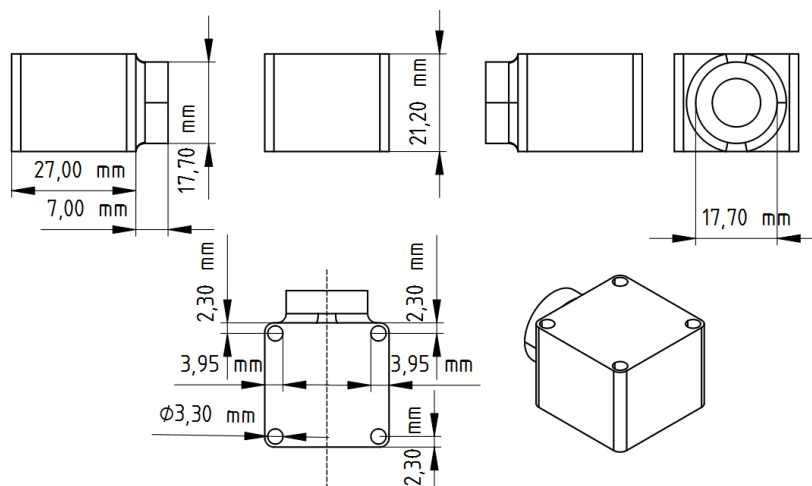

Features

- Sensor successfully tested according EN 50155
- Very Low Noise Differential Voltage Output
- DC Response, Gas damped
- High Shock Resistance
- Excellent Offset and Scale Factor Stability

Options

- Customized Cable Length
- Customized Connector
- Selectable Axes Configuration

Applications

The application-specific housing enables reliable operation even in harshest environmental conditions. They are ideally suited for bogie stability tests and monitoring applications of vehicles and their components in the rail transport sector.

More applications in several markets are figured out on our web page www.asc-sensors.de

Typical Specification

Dynamic

Measurement Range	g	±2	±5	±10	±25	±50	±100	±200	±400
Scale Factor (sensitivity)	mV/g	2000	800	400	160	80	40	20	10
Noise Density	µg/√Hz	7	12	18	25	50	100	200	400
Min. Frequency Response Range (±5 %)	Hz	0 to 100	0 to 100	0 to 300	0 to 500	0 to 650	0 to 650	0 to 1000	0 to 1000
Max. Frequency Response Range (±3 dB)	Hz	0 to 525	0 to 800	0 to 1100	0 to 1750	0 to 2100	0 to 3000	0 to 3600	0 to 4200
Amplitude Non-Linearity	% FSO	<0.15 (typ) <0.5 (max)							
Transverse Sensitivity	%	<2 (typ) <3 (max)							

Electrical

Power Supply Voltage	V	6 to 40							
Operating Current Consumption	mA	<20							
Offset (bias)	mV	±80	±80	±40	±40	±40	±40	±40	±40
Broadband Noise (over min frequency range ±5 %)	µV	140	95	125	90	100	100	125	125
Output Impedance	Ω	90							
Isolation	Integrated electronic circuitry is isolated from the sensor housing Sensor housing and cable shielding are internally connected								

Environmental

Temperature Coefficient of the Scale Factor (max)	ppm/K	±200							
Temperature Coefficient of the Offset (max)	mg/K	±0.8	±2	±4	±10	±20	±40	±80	±160
Operating Temperature Range	°C	-40 to +100							
Storage Temperature Range	°C	-40 to +100							
Shock Limit (max peak)	g	2000	2000	5000	5000	5000	5000	5000	5000
Protection Class	IP68 Please note: the housing is laser-welded and therefore not repairable.								

Physical

Sensing Element	MEMS Capacitive								
Case Material	Stainless-Steel including M12x1.5 rail certified cable gland (complying to EN 45545)								
Connector at Cable End	Optional								
Mounting	Adhesive Screw Holes								
Weight (without cable)	gram	95							
Cable (uniaxial)	RADOX TENUIS-TW 4 x 0.5 mm ² 56 gram per meter Diameter 5.4 ± 0.3 mm								
Cable (biaxial)	RADOX TENUIS-TW 6 x 0.5 mm ² 82 gram per meter Diameter 6.5 ± 0.3 mm								

Inertial sensors of the ASC RAIL series meet applicable EN 50155 standards

The following tests have been performed according to railway standard EN 50155, to confirm climatic resistance and dynamic-mechanical robustness:

- Low temperature storage test – test A according to EN 50155 § 13.4.6 and IEC 60068-2-1
- Low temperature start-up test – test A (OT6) according to EN 50155 § 13.4.4 and to IEC 60068-2-1
- Dry heat test – test B (OT6) according to EN 50155 § 13.4.5 and to IEC 60068-2-2
- Damp heat, cyclic – test Db according to EN 50155 § 13.4.8 and to IEC 60068-2-30
- Insulation tests (before and after damp heat, cyclic) according to EN 50155 § 13.4.7
- Vibration, broad-band random – long time test Fh (category 3: axle mounted) according to IEC 61373 § 9 and IEC 60068-2-64
- Vibration, broad-band random – functional test Fh (category 3: axle mounted) according to IEC 61373 § 8 and IEC 60068-2-64
- Shock testing – test Ea (category 3: axle mounted) according to IEC 61373 § 10 and IEC 60068-2-27

Further, interference emission and interference immunity tests were conducted according to standard EN 50121, confirming electromagnetic compatibility:

- Conducted continuous disturbance at battery port according to EN 50121-3-2:2016/A1:2019 and EN 61000-6-4:2007 + A1:2011
- Radiated disturbance, electrical field according to EN 50121-3-2:2016/A1:2019 EN 61000-6-4:2007 + A1:2011
- Immunity radiated electromagnetic fields according to EN 50121-3-2:2016/A1:2019
- Conducted immunity, injected currents according to EN 50121-3-2:2016/A1:2019
- EFT / Burst according to EN 50121-3-2:2016/A1:2019
- Electrostatic discharge test / ESD according to EN 50121-3-2:2016/A1:2019

Robust solutions ready for stable long-term performance

In addition, all components of the ASC RAIL series were confirmed to meet the latest fire protection standards including EN 45545 for electronic equipment on rolling stock. This includes a reliable, robust, non-flammable stainless-steel housing (V2A material number 1.4301). It is laser-welded leading to protection class IP68.

The cable gland meets all requirements for use in rail transport. VariaPro Rail was tested according fire protection standards DIN EN 45545-2 and 45545-3.

Furthermore, rail certified and integrated cable RADOX TENUIS-TW 600V MM S complies with the technical requirements of EN 50306 (particularly low temperature and high level of oil and fuel resistance). It provides a high level of thermal resistance due to standard fire protection on railway vehicles according to:

- BS 6853, GM/RT 2130
- DIN 5510-2
- EN 45545
- GOST 31565
- NF F 16-101
- NFPA 130
- UNI CEI 11170

Jointly with the proven in-built technologies it leads to a reliable sensor ecosystem to withstand the hardest shocks, vibrations, temperatures and other adverse conditions typically encountered in rail applications. This ensures optimal performance and stable long-term operation of the sensor solutions even under the harshest conditions.

MEMS Capacitive Accelerometer for Railway Applications

Sensor Calibration

Factory Calibration (supplied with the sensor)

Part Number		#12054	#12054	#14514	#14523	#14527	#14527	#14531	#14531
Measurement Range (sensor)	g	±2	±5	±10	±25	±50	±100	±200	±400
Applied Frequency (min)	Hz	1	1	10	10	10	10	10	10
Applied Frequency (max)	Hz	100	100	300	500	650	650	1000	1000
Input Amplitude	m/s ²	5	5	50	100	200	200	200	200
Reference Frequency for Determination of Scale Factor	Hz	16	16	80	80	80	80	80	80

Calibration according DIN ISO 17025 (order separately)

Part Number		#14512	#14512	#14516	#14525	#14529	#14529	#14533	#14533
Measurement Range (sensor)	g	±2	±5	±10	±25	±50	±100	±200	±400
Applied Frequency (min)	Hz	0.5	0.5	10	10	10	10	10	10
Applied Frequency (max)	Hz	150	150	500	800	1600	1600	2000	2000
Input Amplitude	m/s ²	5	5	50	100	200	200	200	200
Reference Frequency for Determination of Scale Factor	Hz	16	16	80	80	80	80	80	80

Please note: The conversion factor 1 g corresponds to 9.80665 m/s². If any other calibration procedure is required, don't hesitate to contact us.

Cable Configuration

4 Wire System - 4L (Uniaxial)

Common power supply for all axes, no cable switch



6 Wire System - 6L (Biaxial)

Common power supply for all axes, no cable switch



6 Wire System - 6L2 (Biaxial)

Common power supply for all axes, including cable switch

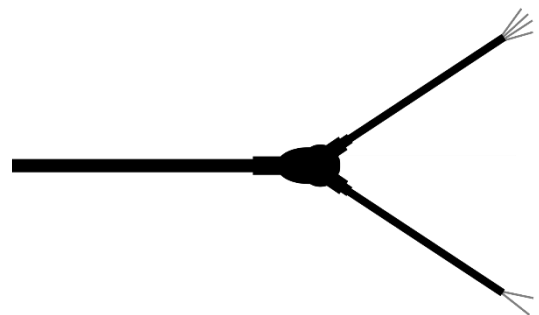

MEMS Capacitive Accelerometer for Railway Applications

Shielding

The integrated electronic circuitry is isolated from the sensor housing. The conductive stainless-steel sensor housing and the cable shielding are internally connected. Therefore, take care of the complete shielding concept according to your application and mounting of the sensor.

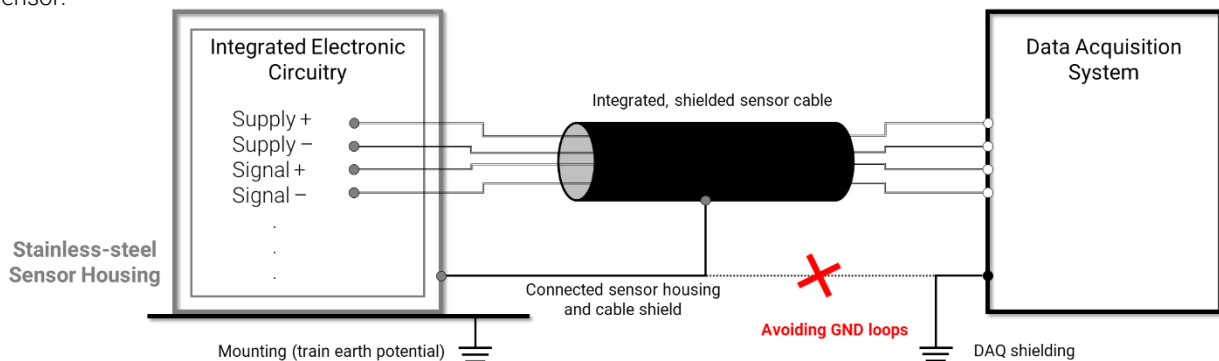

Cable Code / Pin Configuration (4 Wire System) for uniaxial ASC RAIL-1151LN

Pin (black numbered)		Description
1	Supply +	power supply voltage +6 to +40 VDC
2	Supply -	power GND
3	Signal +	positive, analog output voltage signal for differential mode
4	Signal -	negative, analog output voltage signal for differential mode

Cable shielding is provided as a tinned-copper braiding which is also internally connected to the sensor housing

Cable Code / Pin Configuration (6 Wire System) for biaxial ASC RAIL-2151LN

Pin (black numbered)		Sensitive Directions	Description
1	Supply +	Common power supply for all axes	power supply voltage +6 to +40 VDC
2	Supply -		power GND
3	Signal +	X-Axis:	positive, analog output voltage signal for differential mode
4	Signal -	X-Axis:	negative, analog output voltage signal for differential mode
5	Signal +	Y-Axis:	positive, analog output voltage signal for differential mode
6	Signal -	Y-Axis:	negative, analog output voltage signal for differential mode

Cable shielding is provided as a tinned-copper braiding which is also internally connected to the sensor housing

Ordering Information

Series	Model	Range [g]	Cable Length [m]	Connector & Pinout	Cable Configuration
ASC RAIL	1151N (Uniaxial)	002	6	A	4L (Uniaxial)
	2151N (Biaxial)	005			6L (Biaxial)
		010			6L2 (Biaxial)
		025			
		050			
		100			
		200			
	400				

Example:

ASC RAIL-1151LN-002-6A-4L

Ordering information are based on standard configurations. All customized versions regarding connector and/or pinout will lead to a corresponding product match code:

- Standard length of the integrated cable is 6 meters. However, different customized cable lengths are possible on request.
- Standard version has no connector at the cable end which is identified by "A" in the product match code. However, it is possible to assemble almost all connector types during production.
- Furthermore, sensors have to be calibrated regularly to ensure accurate and precise results. Our services include both factory calibration and calibration in accordance with DAkkS guidelines. On request we will be glad to remind you of the next scheduled calibration of your sensors.

ASC RAIL sensors to improve railway performance

ASC's RAIL sensor series provides high-precision, robust yet flexible inertial sensor technologies. The tailored solutions support railway customers in improving the safety, capacity and overall productivity of their rolling stock. Pre-qualified accelerometers of type ASC RAIL-x152LN are already being used by European and global rail operators. In June, 2024, the sensor series was expanded with an additional accelerometer type ASC RAIL-x151LN, featuring a more compact housing to be able to fit into smaller spaces. The same smaller housing was used for the new gyroscopes of type ASC RAIL-27x1. For all three models, comprehensive evaluations by an independent testing lab resulted in clear outcomes for ASC's reliable, accurate RAIL series.

Current data sheet

ASC RAIL-x151LN

Accelerometers
uniaxial or biaxial
±2 to ±400 g



Alternatives | Options of the ASC RAIL sensor series

ASC RAIL-x152LN

Accelerometers
up to 3 sensitive directions
±2 to ±400 g



ASC RAIL-27x1

Gyroscopes
up to 3 sensitive directions
±75 to ±900 °/s



Safety Precaution for Installing and Operating

This data sheet is a part of the product. Read the data sheet carefully before using the product and keep it available for future operation. Handling, electrical connections, mounting or any other work performed at the sensor must be carried out by authorized experts only. Appropriate safety precautions must be taken to exclude any risk of personal injury and damage to operating equipment as a result of a sensor malfunction.

Handling

The sensor is packaged in a reliable housing to protect the sensing elements and integrated electronic components from the ambient environment. However, poor handling of the product can lead to damages that may not be visible and cause electrical failure or reliability issues. Handle the component with caution:

- Avoid shocks and impacts on the housing, such as dropping the sensor on hard surface
- Never move the sensor by pulling the cable
- Make sure that the sensor is used within the specified environmental conditions
- Transport and store the sensor in its original or similar packaging
- The sensor should be mounted on a stable flat surface with all screws tightened or other mounting options
- When adhesives are used to mount the sensors, please select the corresponding products according to permanent or removable mounting, ambient temperature range as well as quality of the mounting surface
- Avoid any deformation during mounting the sensor
- Mounting tolerances may have an influence on the measured result

Electrical

ASC's inertial sensors are working with many established data acquisition systems. However, make sure that a proper DAQ is used, for the corresponding operation principle of the sensor. Furthermore, suitable precautions shall be employed during all phases of shipment, handling and operating:

- Active sensor pins are susceptible to damage due to electrostatic discharge (ESD)
- Make sure that the sensor is used within the specified electrical conditions
- Check all electrical connections prior to initial setup of the sensor
- An incorrect wiring of the signal or power supply connections will lead to damages of the sensor
- Completely shield the sensor and connecting cable according to your application
- Do not perform any electrical modifications at the sensor
- Do not perform any adaptations on the wiring or connectors while the device under power
- Never plug or unplug the electrical connection while the sensor is under power
- When a certain pin is not used during operation, make sure that the pin is insulated

Quality

- We have a quality management system according to **ISO 9001:2015**.
- The Deutsche Akkreditierungsstelle GmbH (DAkkS) has awarded to our calibration laboratory the **DIN EN ISO/IEC 17025:2018** accreditation for calibrations and has confirmed our competence to perform calibrations in the field of mechanical acceleration measurements. The registration number of the certificate is **D-K-18110-01-00**.
- The sensors described in the data sheet are **CE**-compliant.

Made in Germany



analyzing



monitoring



testing



measuring