

Clinometer Pak 420



850 Perimeter Road

Manchester, NH 03103 USA

Phone: 603-669-6400

Fax: 603-622-2690

www.jewellinstruments.com

sales@jewellinstruments.com

WARNING!

NEVER USE AN OHMMETER TO MEASURE THE TILT SENSORS INSIDE THE TILTMETER. APPLYING DC CURRENT THROUGH THE SENSORS WILL CAUSE PERMANENT DAMAGE THAT IS NOT COVERED BY THE WARRANTY.

Copyright ©2014 by Jewell Instruments LLC. All rights reserved.
Manual No. B-04-1001, Rev. A. Printed in USA.

TABLE OF CONTENTS

1	Introduction	1
2	Technical Features	3
3	Specifications.....	3
4	Wire Color Code and Connector Pin Designations	6
5	Tiltmeter Operation	7
5.1	<i>Initial Check-Out Procedures</i>	<i>7</i>
5.2	<i>Tiltmeter Installation and Transient Protection.....</i>	<i>7</i>
6	Converting Current Readings to Tilt Angles	12
7	Temperature Measurement	12
8	Measuring and Removing Zero Offset (Bias)	18
9	Maintenance and Troubleshooting	19
9.1	<i>Routine Maintenance</i>	<i>19</i>
9.2	<i>Determining the Cause of Malfunctions.....</i>	<i>19</i>
10	Warranty and Assistance.....	20
A	How the Sense Resistor Changes the Voltage Requirement	A1
B	Custom Specifications for Your Equipment	B1
C	Revision Table.....	C1

Table of Figures

Figure 1. Clinometer Pak 420 dimensions	1
Figure 2. Tilt directions	2
Figure 3. Enclosure and mounting hole dimensions.....	5
Figure 4. Wiring diagram for the Clinometer Pak 420 Uniaxial	6
Figure 5. Mounting screw insertion	9
Figure 6. Using P/N 81439 Mounting Bracket.....	10
Figure 7. Using P/N 84051 Mounting Plate.....	10
Figure 8. Double-nutted mounting screws for fine level adjustment.....	11
Figure 9. Thermistor resistance vs. temperature, -50° to +70°C	15
Figure 10. Thermistor resistance vs. temperature, -40° to +50°C	16
Figure 11. Thermistor resistance vs. temperature, 0° to +50°C.....	17
Figure 12. Measure the tilt angle in these two positions to compute the tiltmeter bias	18
Figure 13. How the sense and cable resistance affect the minimum power supply voltage	A1

1 Introduction

The Clinometer Pak Tilt 420 is an economical uniaxial tiltmeter in a rugged NEMA 4X (IP65) enclosure (Figure 1). It incorporates a high-precision electrolytic tilt transducer as the internal sensing element, offering unrivaled resolution and long-term stability. Measured angular movement is referenced to the unchanging vertical gravity vector, eliminating the time and expense of locating an external datum. Your Clinometer Pak 420 is ideal for a wide variety of engineering projects including: structural behavior testing, monitoring of foundation conditions, surveillance of natural and manmade structures, and machine positioning and control. The Clinometer Pak 420 is loop-powered. No separate power supply is required to power your tiltmeter, as it takes its power from the current loop. A temperature sensor also is included in your Clinometer Pak 420. Output is a DC current proportional to temperature in degrees Celsius. Current is measured indirectly using a sense resistor, R . Ohm's Law states that $V_1 - V_2 = IR$, where I is current in Amperes, R resistance in Ohms, and V_1 and V_2 the voltages measured on opposite sides of the sense resistor.

Clinometer Pak 420 tiltmeters are available in high-gain ($\pm 0.5^\circ$ range), standard ($\pm 3^\circ$ range) and wide-angle ($\pm 50^\circ$ range) versions. Each of these versions is produced in both longitudinal and transverse tilt styles (Figure 2). Range and tilt style are specified when ordering.

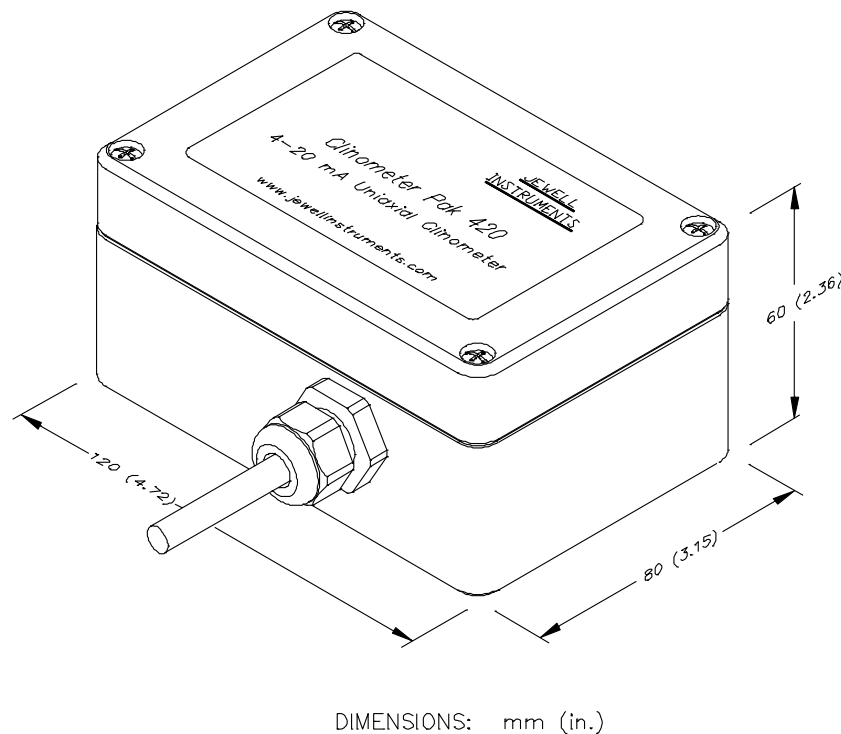

Figure 1. Clinometer Pak 420 dimensions

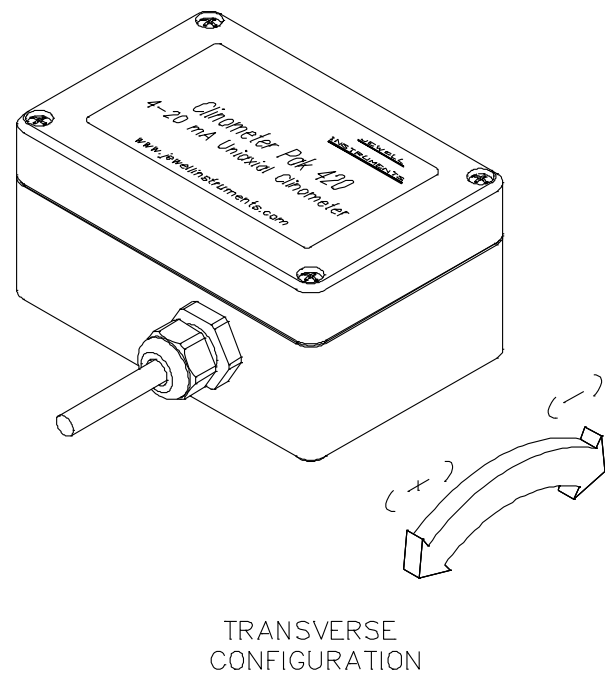
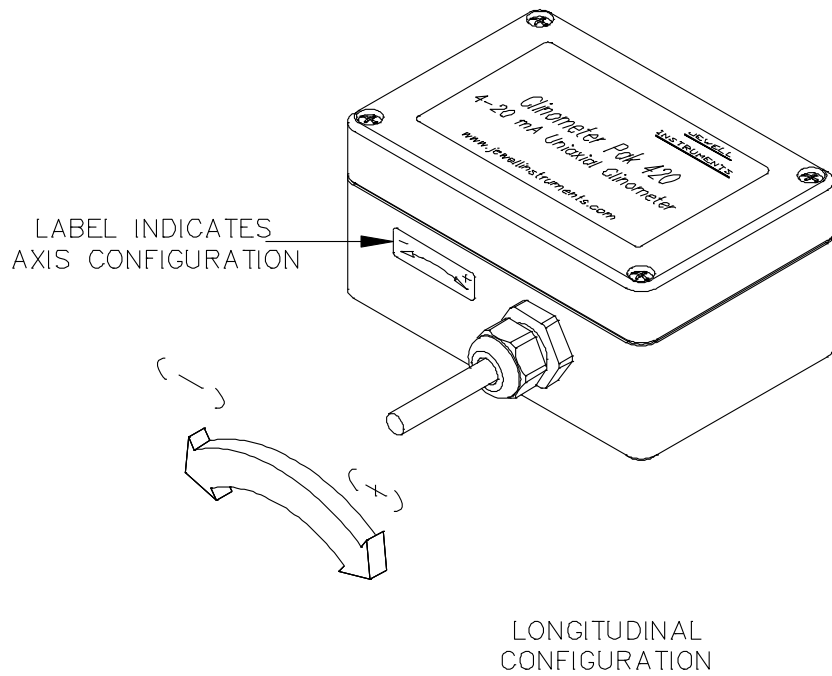

Figure 2. Tilt directions

Technical Features

Your Clinometer Pak 420 Uniaxial Tiltmeter is rugged and field-proven - intended for use in harsh outdoor environments, in the laboratory, or on the factory floor. The tilt sensor and electronic signal conditioning circuitry are housed in a NEMA 4X rated, die-cast aluminum enclosure. Holes in the enclosure, accessed by removing the cover, are provided for mounting the tiltmeter. (See section 5.2, Tiltmeter Installation, for details and figures.) High-reliability components and surge protection enhance performance under electrically noisy or transient-prone conditions. A low-pass filter removes vibration effects for static measurements. A built-in temperature sensor provides the data necessary for analysis of thermal deformation and stresses.

Your tiltmeter senses angular movement (rotation) with respect to the vertical gravity vector. The sensing element is an electrolytic tilt transducer, similar to a spirit level. As the transducer tilts, internal electrodes are covered or uncovered by a conductive fluid. This process produces changes in electrical resistance when an AC excitation is passed through the transducer. These changes are measured using a voltage divider network. The resulting signal is then amplified, actively rectified and filtered to form a DC current signal that is proportional to the measured angular rotation, or tilt.

Other important features include the following:

- All electronics reside on a single internal printed-circuit board.
- All circuit board external connections are gold-plated for long life and noise-free operation.
- All resistors are premium quality, 1% tolerance, metal-film type.
- All tiltmeters are hand-assembled, calibrated, and tested at our plant under stringent quality control standards.
- Jewell Instruments maintains complete specifications and test records of every tiltmeter built.

Specifications

	High-Gain Version	Standard Version	Wide-Angle Version
ANGULAR RANGE	±10 degrees	±25 degrees	±50 degrees*
SCALE FACTOR†	1.25°/ mA typical	3.125°/ mA typical	6.25°/ mA typical
RESOLUTION	<0.005 degree	0.01 degree	0.02 degree
REPEATABILITY	<0.01 degree	0.02 degree	0.04 degree
HYSTERESIS	<0.02 degree	<0.02 degree	<0.04 degree
LINEARITY	1% of full span typical	<1% of half span, 2.5% of full span typical	1.2% of half span, 7.5% of full span typical
TILT OUTPUT	4-20 mA current loop		
POWER REQUIREMENTS	$V_s = 0.02 \text{ Amp} \times R_{\text{max}} + 10 \text{ VDC}$ Where: V_s = DC power supply voltage, and R_{max} = maximum resistance of the loop wiring + sense resistor. <i>Maximum V_s = 29 VDC</i>		
TIME CONSTANT, T	150 msec, output is proportional to $1 - e^{-t/T}$ where t = time in seconds		
NATURAL FREQ.	10 Hz; available with viscous sensor to damp vibrations		
TEMPERATURE COEFFICIENT	Span: 0.03%/°C, Zero: 10-20 Arc Sec./°C typical		
TEMPERATURE OUTPUT	25°C = 2500 Ohms, -50 to +150°C. Temperature is measured with a 2500 Ohm thermistor.		
ENVIRONMENTAL	-40° to +85° C operating and storage		
ENCLOSURE & MOUNTING	NEMA 4X (IP65) painted aluminum box, 120 x 80 x 60 mm. Four 4.4 mm diameter mounting holes at corners of 107 x 67 mm rectangle. (See Figure 3.)		
CABLE	10 ft (3 m), 6-conductor + one overall shield, PVC jacket, tinned ends; greater lengths on request		
WEIGHT	1.2 lb (0.5 kg)		

* greater range available

† Divide by 2 for differential scale factor.

Ordering Information

High-Gain Version	±10 degrees range
Standard Version	±25 degrees range
Wide-Angle Version	±50 degrees range

To add the following features, specify option code after Model Number

Option Code	Feature
P/N 70304	Additional cable, specify length
P/N 62204	6-pin male receptacle (connector) for tiltmeter cable
P/N 62202	6-socket in-line plug (mates to P/N 62204)
01439	Mounting bracket for vertical surfaces
84051	Mounting plate for horizontal surfaces

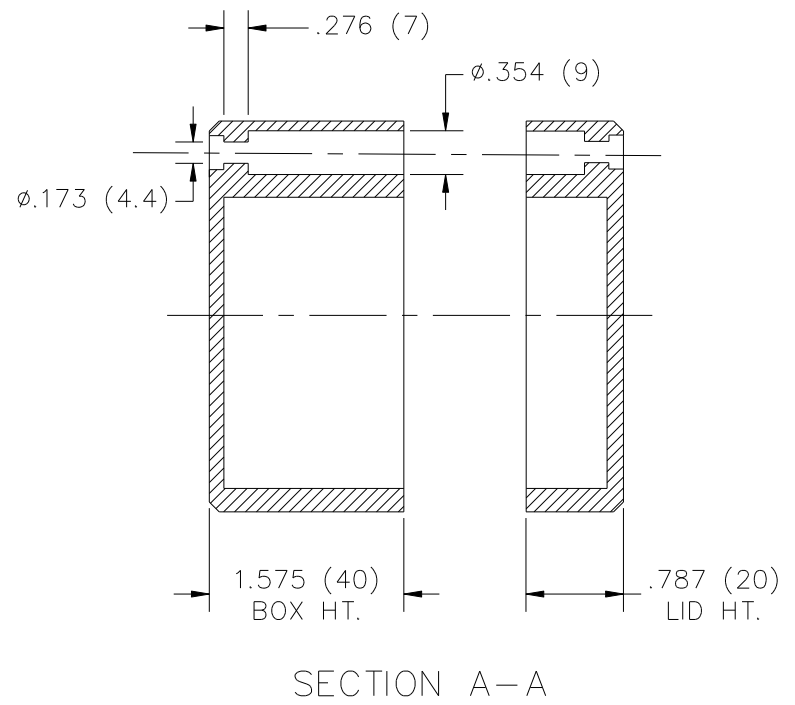
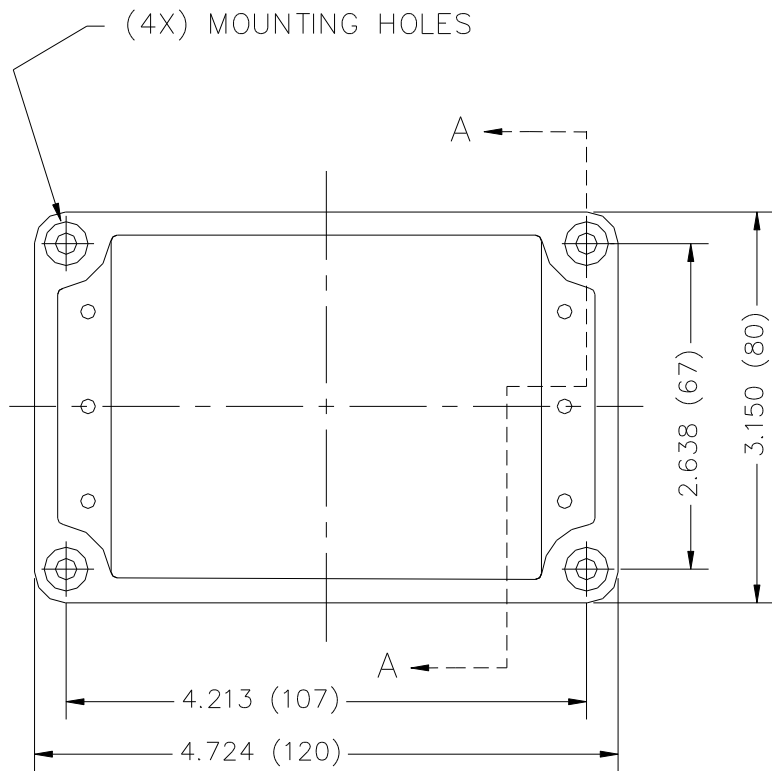

DIMENSIONS IN inches (mm)

Figure 3. Enclosure and mounting hole dimensions

Wire Color Code and Connector Pin Designations

Color coding of the wires in the Clinometer Pak 420 cable is shown in Table 1. J2 is the white connector on the printed circuit board inside the tiltmeter. Figure 4 shows the wiring diagram. The sense resistor, R in Figure 4, is usually not needed unless a data logger is used. The current can be measured directly using an ammeter between V_1 and V_2 of the current loop in Figure 4, with no sense resistor. The ammeter will be connected between the loop return (ground) wire of the cable and the power supply ground, located at the end of the cable farthest from the tiltmeter. When no sense resistor is present, only the cable resistance affects the minimum power supply voltage, as explained in Appendix A.

Table 1. Uniaxial Configuration Wire Color Code and Connector Pin Designations		
Function	Wire Color	J2 Pin Number
Loop Power (V_{supply})	Red	1
Loop Return (Ground)	Black	2
Temperature Excitation (up to 12 VDC)	Blue	3
Temperature Out	Yellow	4
Temperature Return	White	5
Drain Wire (Shield)	Bare (Clear)	None

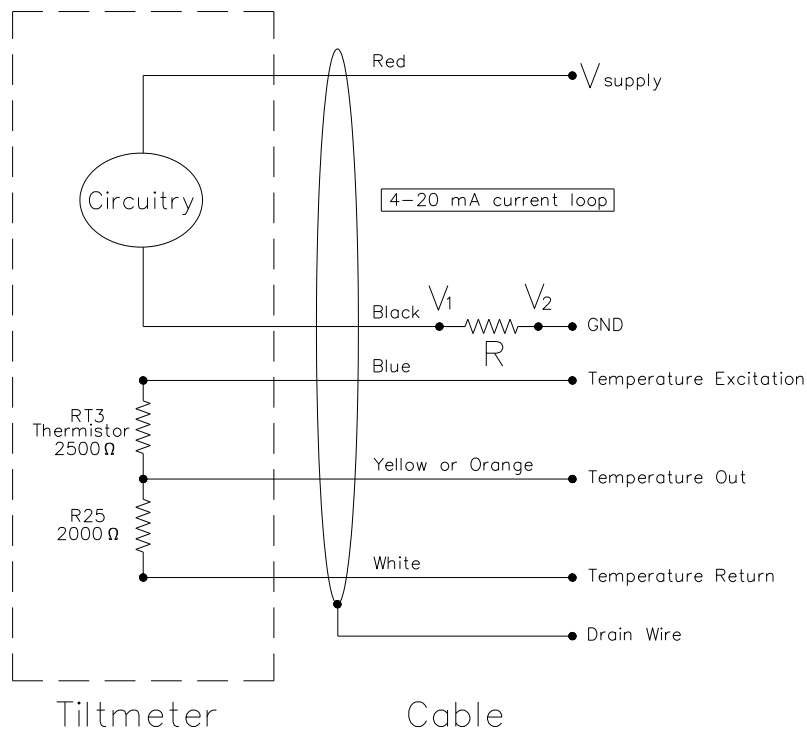

Figure 4. Wiring diagram for the Clinometer Pak 420 Uniaxial

5 Tiltmeter Operation

5.1 Initial Check-Out Procedures

Before installing your tiltmeter, verify that it is functioning properly by following the steps below:

1. Connect the tiltmeter to a power supply. The power supply should be connected between V_{supply} and GND of the current loop in Figure 4.
2. Connect the tiltmeter to an ammeter. The ammeter should be connected between V_1 and V_2 of the current loop in Figure 4.
3. Refer to the (+) and (-) tilt directions in Figure 2 (also shown on a label on your tiltmeter). With the tiltmeter in your hands, rotate it to verify the sign (polarity) of the current outputs on the ammeter. A rotation in the (+) direction should make the current output increase.
4. Check that the tiltmeter output moves through its full range of approximately 4 mA to 20 mA on the ammeter display.
5. Verify that the temperature sensor output accurately approximates the temperature in your location. Connect an ohmmeter between Temperature Excitation and Temperature Out. (Figure 4 shows the wiring diagram.) For example, a temperature of 25°C (77°F) should give a current output of 2500 Ohms. See the graph in Figure 11 for the upper half of the temperature sensor scale. Section 7, Temperature Measurement, explains the process in detail.

5.2 Tiltmeter Installation and Transient Protection

Your Clinometer Pak 420 Tiltmeter is designed to be mounted directly on a solid horizontal surface using four No. 8-32 cap screws, which are supplied with each tiltmeter. The surface may be drilled and tapped to accept the screws, or through-holes may be drilled and the screws attached with nuts and washers on the underside of the surface. The mounting holes are accessed by first removing the tiltmeter cover (Figure 6). The mounting hole pattern and dimensions are shown in Figure 3. The mounting holes are 4.4 mm (0.173 inch) in diameter and accept a no. 8 screw. For mounting on vertical surfaces, the optional Mounting Bracket can be used (part no. 81439, Figure 6). For mounting on horizontal surfaces, the optional Mounting Plate is used (part no. 84051, Figure 7).

It is also possible to use a double-nutted mounting arrangement to allow for leveling of the tiltmeter (Figure 8). This technique is typically used with the high-gain tiltmeter because of its narrow angular range. It is important to adjust the leveling nuts slowly in sequence while observing the readout to obtain level (reading of approximately 12 mA).

Other methods have also been used successfully to install Clinometer Pak 420 tiltmeters. For example, in ground movement monitoring applications, a shallow hole may be dug and then partially filled with dry

sand. The tiltmeter can then be placed directly on the sand and leveled by hand. This method is often effective if the tiltmeter is unlikely to be disturbed during the monitoring period. If placed in a hole, care should be taken to prevent flooding of the tiltmeter during wet weather.

It is sometimes possible to clamp the tiltmeter to a metal plate or flange. “C” clamps may be used for this purpose.

Your Clinometer Pak 420 is reverse polarity protected but is not surge (transient) protected. A high-voltage transient exceeding the 29 VDC input range could damage the electronics.

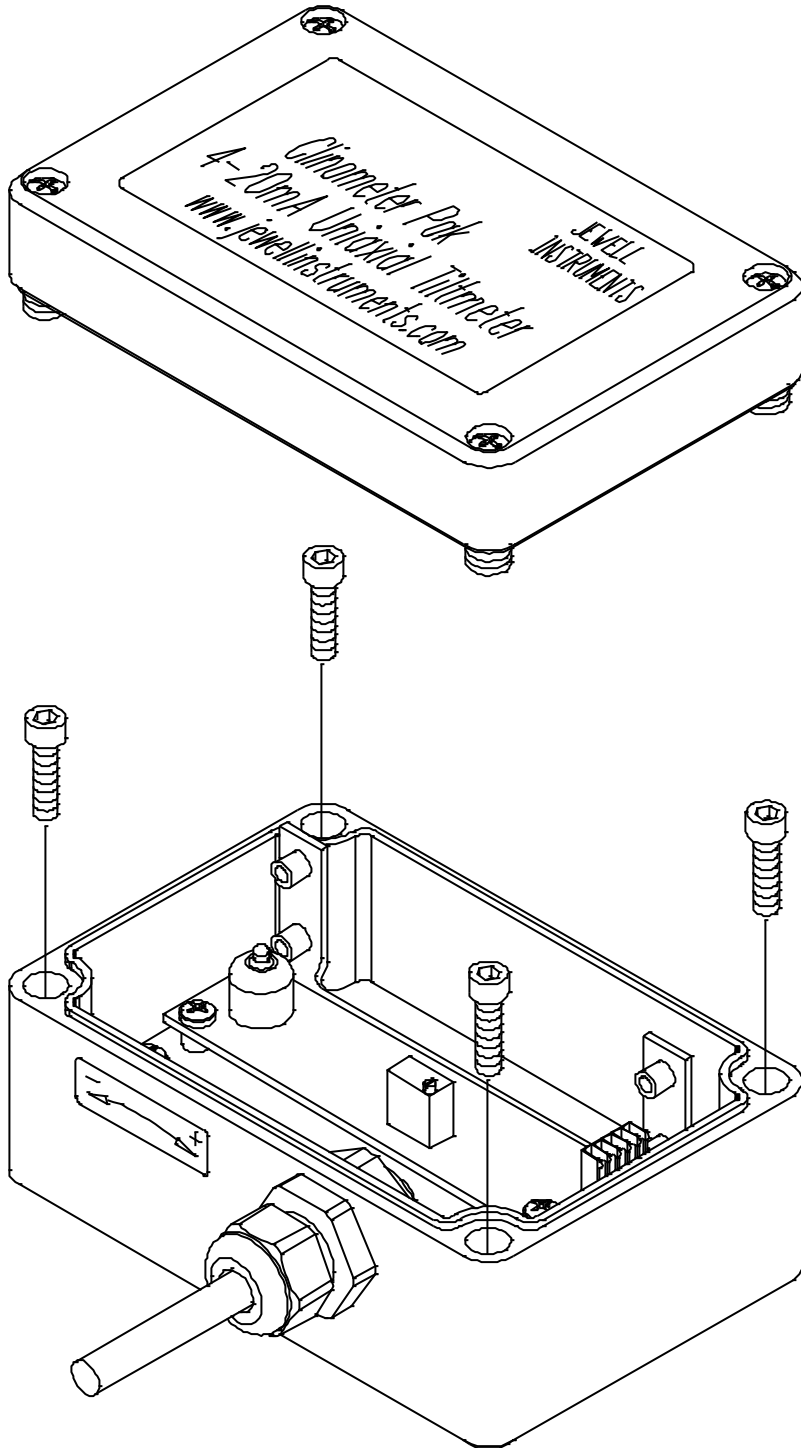

Figure 5. Mounting screw insertion

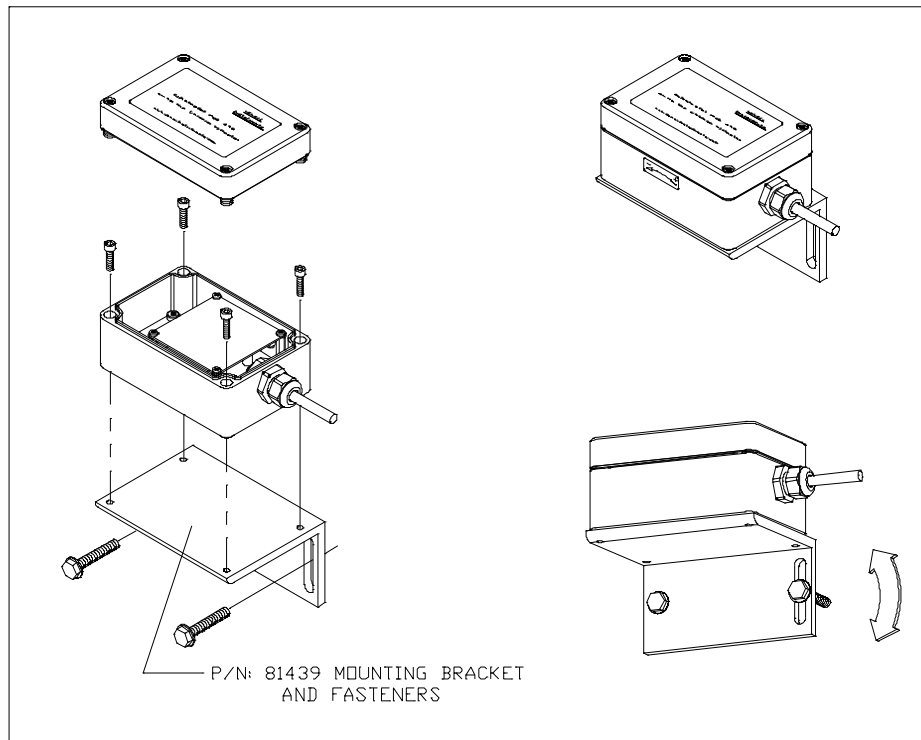

Figure 6. Using P/N 81439 Mounting Bracket

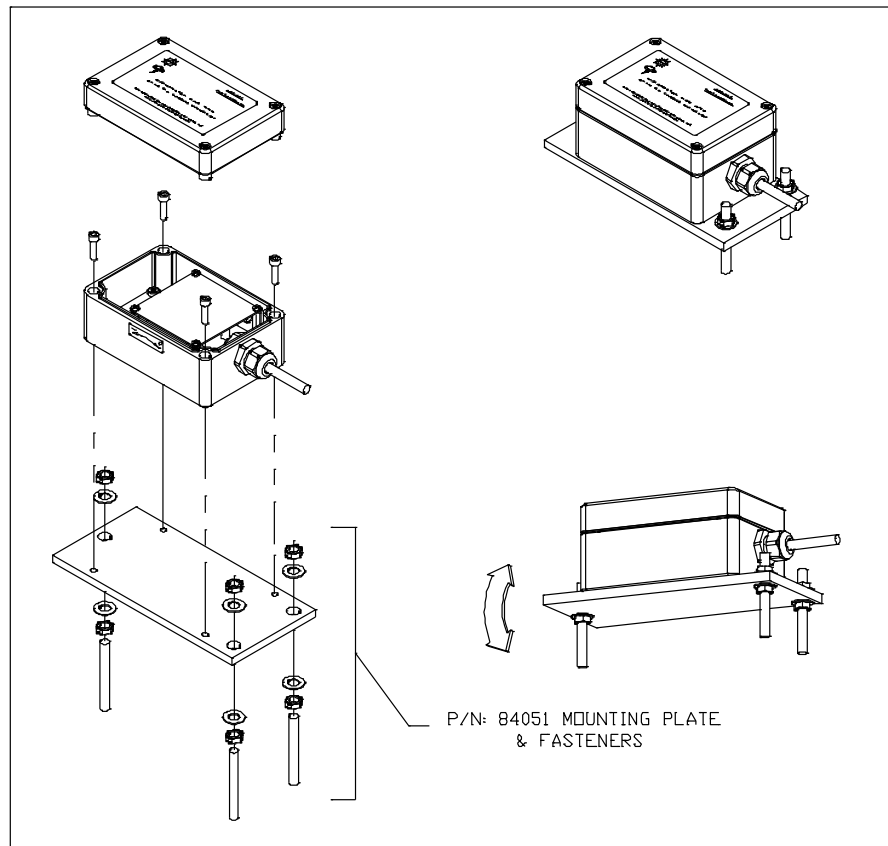

Figure 7. Using P/N 84051 Mounting Bracket

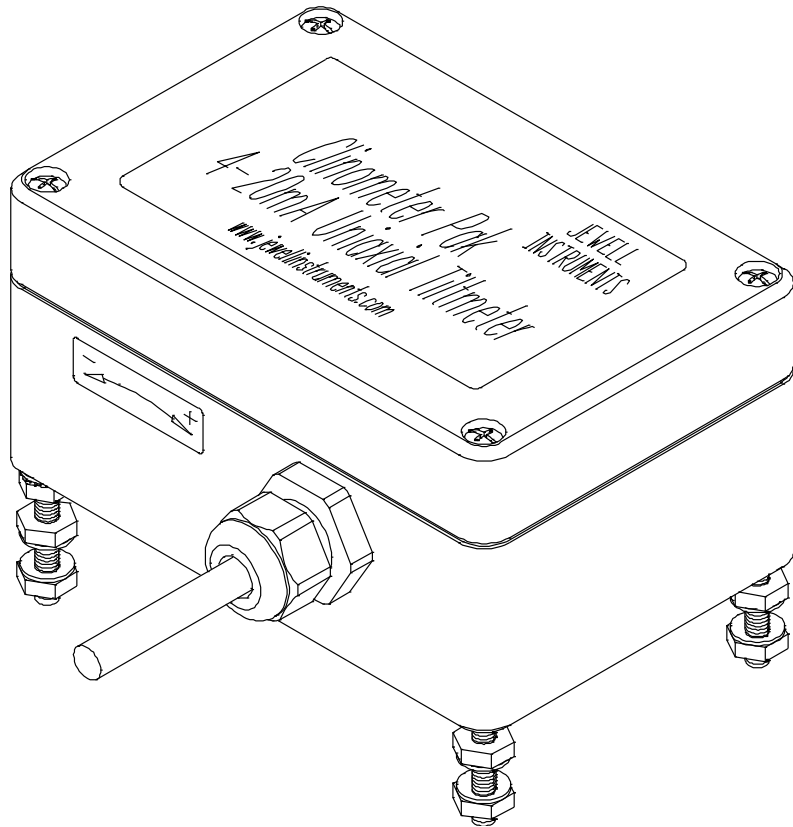

Figure 8. Double-nutted mounting screws for fine level adjustment

6 Converting Current Readings to Tilt Angles

The current output of the Clinometer Pak 420 is quickly converted to a tilt angle using the scale factor in the Calibration Certificate at the end of this manual. To use the scale factor, simply multiply the current reading by the scale factor. For example, if the scale factor is 1.5 degrees/mA, and the output is +15.000 mA, the tilt angle is $(1.5 \text{ degrees/mA}) \times (15.000 \text{ mA} - 12.000 \text{ mA}) = +4.5 \text{ degrees}$ (including the bias). Note that 12.000 mA is the current reading at 0 degrees, and must be subtracted from the current reading. To convert from degrees to other angle units (arc minutes, mm/meter, etc.), refer to Table 2.

Table 2. Angle Conversion Chart						
	degrees	arc minutes	arc seconds	μradians	mm/mete r	inches/ft
degrees =	1	60	3600	17453	17.45	0.2094
arc minutes =	0.01667	1	60	290.9	0.2909	3.46×10^{-3}
arc seconds =	2.78×10^{-4}	0.01667	1	4.848	4.85×10^{-3}	5.82×10^{-5}
μradians =	5.73×10^{-5}	3.44×10^{-3}	0.2063	1	0.001	1.20×10^{-5}
mm/meter =	0.0573	3.436	206.3	1000	1	0.0120
inches/ft =	4.775	286.5	17,189	83,333	83.33	1

7 Temperature Measurement

Your tiltmeter contains an internal *thermistor* for measuring temperature. This thermistor has a negative temperature coefficient, which means that its resistance decreases as the temperature goes up. Its resistance at 25°C is approximately 2500 Ohms. The wiring diagram for the thermistor, RT3, is shown in Figure 4. When making a temperature measurement, the thermistor should be powered only briefly (<1 second is good) to avoid self-heating.

There are two ways to use the thermistor to measure temperature inside your tiltmeter:

- 1) Measure the thermistor resistance directly using an ohmmeter connected to the “Temperature Excitation” and “Temperature Out” wires, and then convert this resistance to temperature. This conversion may be done with the help of Figures 9, 10 and 11. Figure 9 graphs thermistor resistance vs. the full temperature range of -50° to $+70^{\circ}\text{C}$. Figures 10 and 11 are enlargements of the regions below and above 0°C .

Instead of using a graph, you may compute temperature from thermistor resistance with the following equation:

$$2) \quad T = 1/[A + B \ln(RT3) + C \ln(RT3)^3 + D \ln(RT3)^5] - 273.15 \quad (\text{eq. 1})$$

where T is in degrees Celsius and

RT3 = thermistor resistance

A = 7.34862E-04

B = 3.38205E-04

C = -1.30862E-07

D = 1.21751E-09

- 3) The second method of determining temperature is to use the thermistor RT3 and fixed resistor R25 as a voltage divider (see Figure 4). By applying a known voltage V_{in} at the end of the “Temperature Excitation” wire and measuring the voltage V_{out} on the “Temperature Out” wire, the thermistor resistance is obtained indirectly, as shown below. Both V_{in} and V_{out} are referenced to ground at the end of the “Temperature Return” wire.

The equation for V_{out} is:

$$V_{out} = V_{in} R25 / (RT3 + R25) \quad (\text{eq. 2})$$

Rearranging gives:

$$RT3 = R25(V_{in}/V_{out} - 1) \quad (\text{eq. 3})$$

Note that the value of R25 is 2000 Ohms. As shown by equation 3, the input voltage can vary during your measurements. What is important, however, is that the ratio of the input voltage to the output voltage, V_{in}/V_{out} , be accurately known. Once you have obtained the value of RT3 from equation 3, use Figures 9, 10 and 11 or equation 1 to obtain the internal tiltmeter temperature.

Note: in the biaxial configuration (X and Y tilt), the Clinometer Pak 420 does not include a “Temperature Return” wire. To measure the output of the on-board thermistor in a voltage divider, connect a 2000 Ohm resistor between the tiltmeter’s yellow/orange “Temperature Out” wire and the reference-ground on your datalogging device. The grounded side of this resistor (connected to your datalogger ground) can now be used as your “Temperature Return” wire; follow the instructions above to take temperature measurements in a voltage divider circuit.

If your tiltmeter has a long cable, you will improve the accuracy of your thermistor resistance measurements by subtracting cable resistance from your readings. Jewell Instruments tiltmeter cables contain stranded copper conductor wires with a gauge of 24 AWG. Each wire has a resistance of approximately 26 Ohms per 1000 ft (85 Ohms/km) at 25°C. In the case of a 1000 ft cable and direct resistance measurement using an Ohmmeter, you would subtract 2 x 26 Ohms from your reading to get the true resistance of RT3. Thus, a total of 52 Ohms would be subtracted, accounting for the resistance of the two wires through which the measurement was made. (See Appendix A, Figure A1, for a graph of the sense and cable resistance versus the power requirement for the tiltmeter.)

If you plan to use the voltage divider circuit to determine temperature, equation 2 must be rewritten to account for the resistance R^* of the “Temperature Excitation” and “Temperature Return” wires:

$$V_{out} = V_{in} (R25 + R^*) / (RT3 + R25 + 2R^*) \quad (\text{eq. 4})$$

Rearranging gives this equation for thermistor resistance RT3:

$$RT3 = (R25 + R^*)(V_{in}/V_{out} - 1) - R^* \quad (\text{eq. 5})$$

You must decide whether lead wire resistance is important enough to take it into consideration in your measurements. For temperatures around 25°C and a 500 ft (152m) cable, wire resistance is about 1% of the thermistor resistance. The temperature error caused by not taking wire resistance into consideration is $\ll 1^\circ\text{C}$. In geotechnical and earth science applications temperature trends and relative changes are normally more important than highly accurate absolute temperature readings. In some of these applications lead wire resistance may not be important.

For further information on the properties and use of thermistors for temperature measurement, visit the U.S. Sensor Corp. website, www.ussensor.com. The thermistor used in your tiltmeter has a B type curve and is U.S. Sensor part no. LR252B1K.

**Resistance vs. Temperature for 2500 Ohm Thermistor with B Type Curve
(U.S. Sensors LR252B1K)**

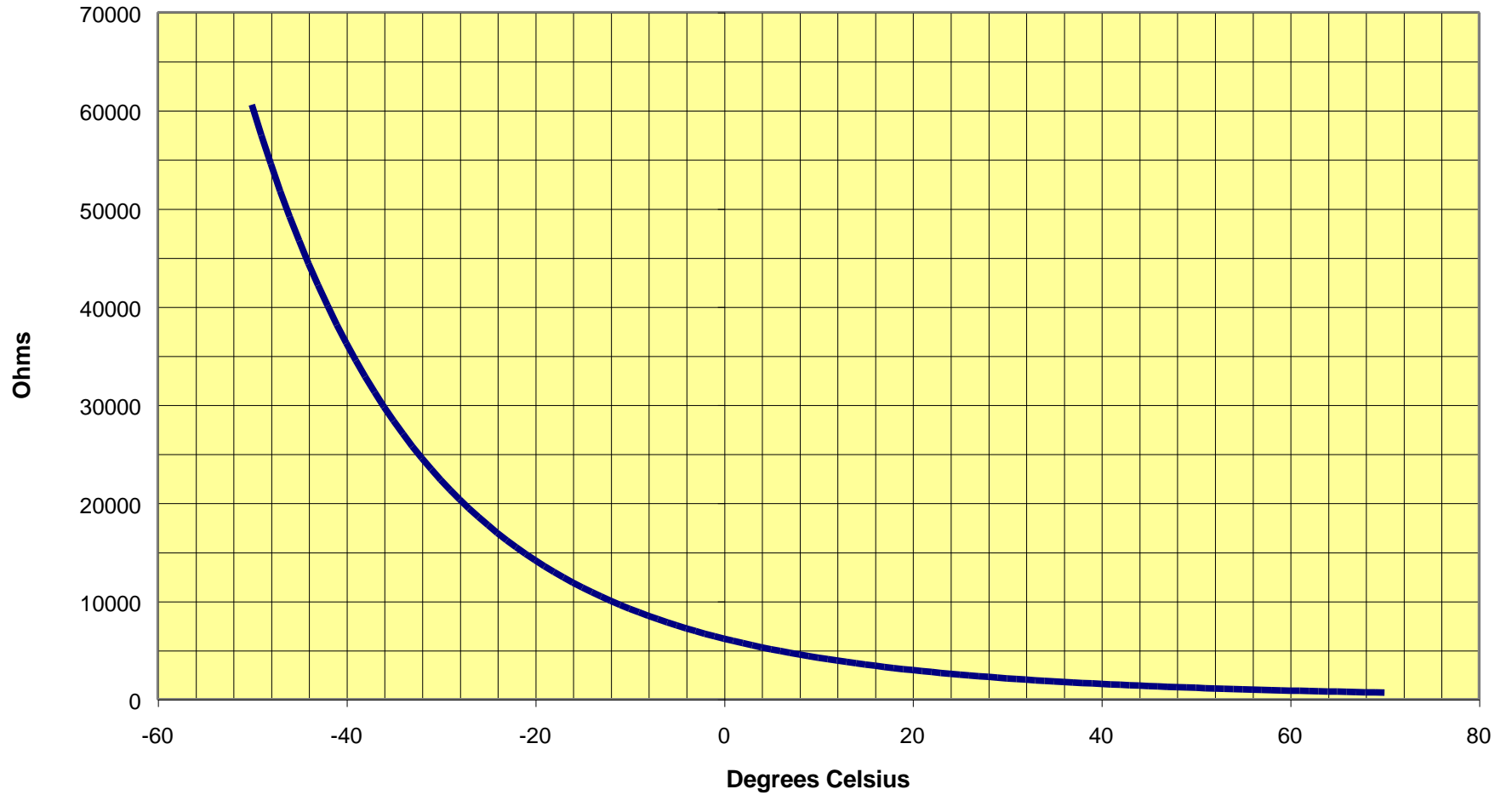

Figure 9. Thermistor resistance vs. temperature, -50° to +70°C

**Resistance vs. Temperature for 2500 Ohm Thermistor with B Type Curve
(U.S. Sensors LR252B1K)**

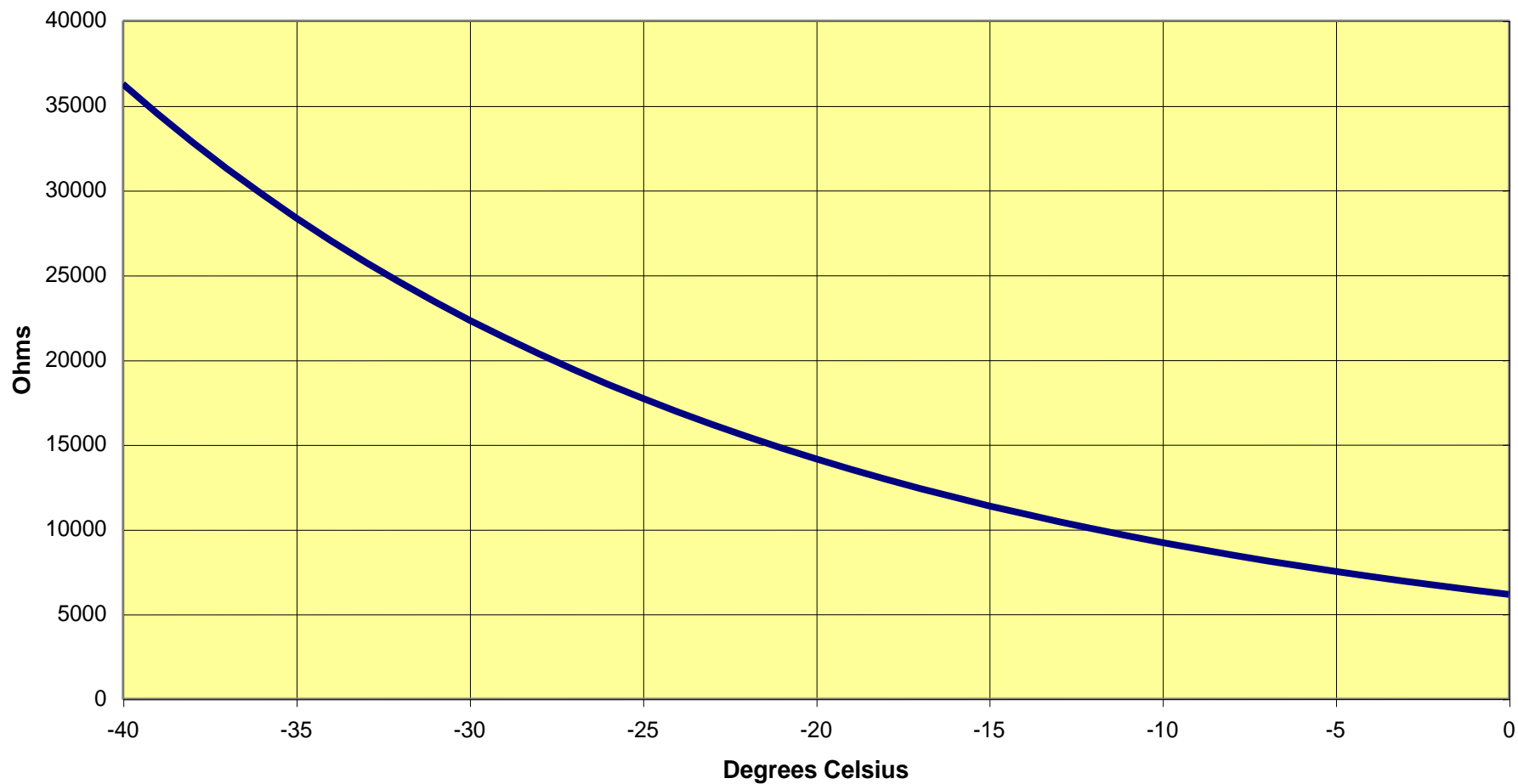

Figure 10. Thermistor resistance vs. temperature, -40° to 0°C

**Resistance vs. Temperature for 2500 Ohm Thermistor with B Type Curve
(U.S. Sensors LR252B1K)**

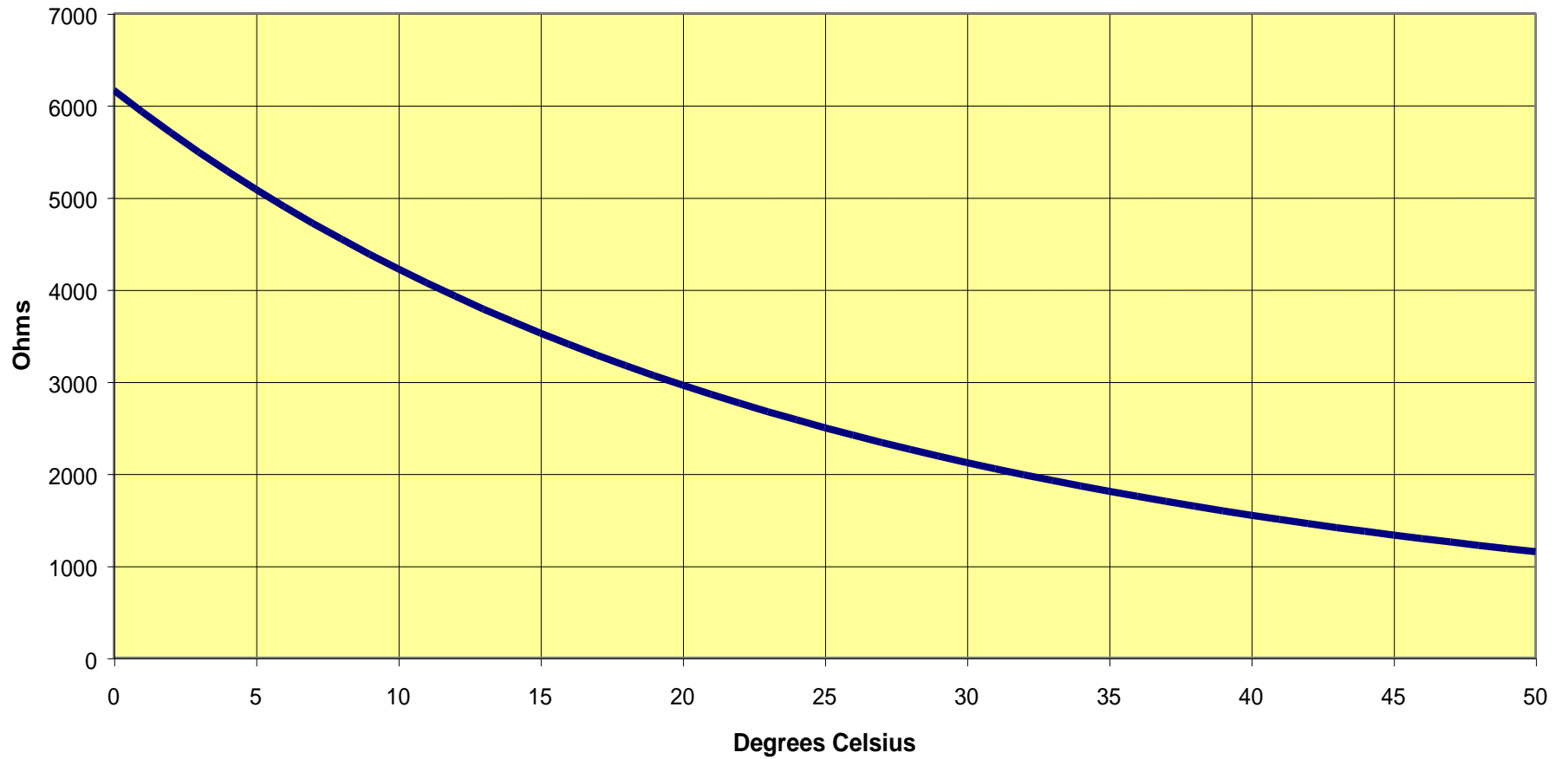

Figure 11. Thermistor resistance vs. temperature, 0° to +50°C

8 Measuring and Removing Zero Offset (Bias)

Bias (B) is defined as the difference between the true angle and the angle reported by the tiltmeter when it is level. Think of a perfectly horizontal surface with your Clinometer Pak sitting on it. If there were no bias, the output would read 12 mA. In reality, the outputs of most tiltmeters do not output exactly 12 mA when level because of mechanical tolerances in the component parts (sensor, screws, standoffs, etc.). Normally, it is not desirable to remove the bias, however it may be necessary for some applications. For example, if you only wish to measure tilt angles relative to a certain surface, you may wish to remove the tiltmeter bias and set your own bias relative to the surface you wish to consider level (0 degrees).

To measure and remove bias, do the following:

Place the tiltmeter on an approximately horizontal surface (table top, granite flat, etc.). Read the output current I_1 and then compute the indicated angle θ_1 by multiplying by the scale factor for your tiltmeter, found in Appendix B, and then adding 12 mA. For example, $\theta_1 = (I_1 \times S) + 12\text{mA}$, where S is the scale factor.

Rotate the tiltmeter 180 degrees on the surface so that it is facing the opposite direction (Figure 12). Read the new output current I_2 and compute the angle θ_2 using the same procedure as in step 1 above. The scale factor is the same for both steps.

The bias is given by the formula $B = (\theta_1 + \theta_2)/2$. Record this bias and subtract it from all subsequent measurements to get the true angle.

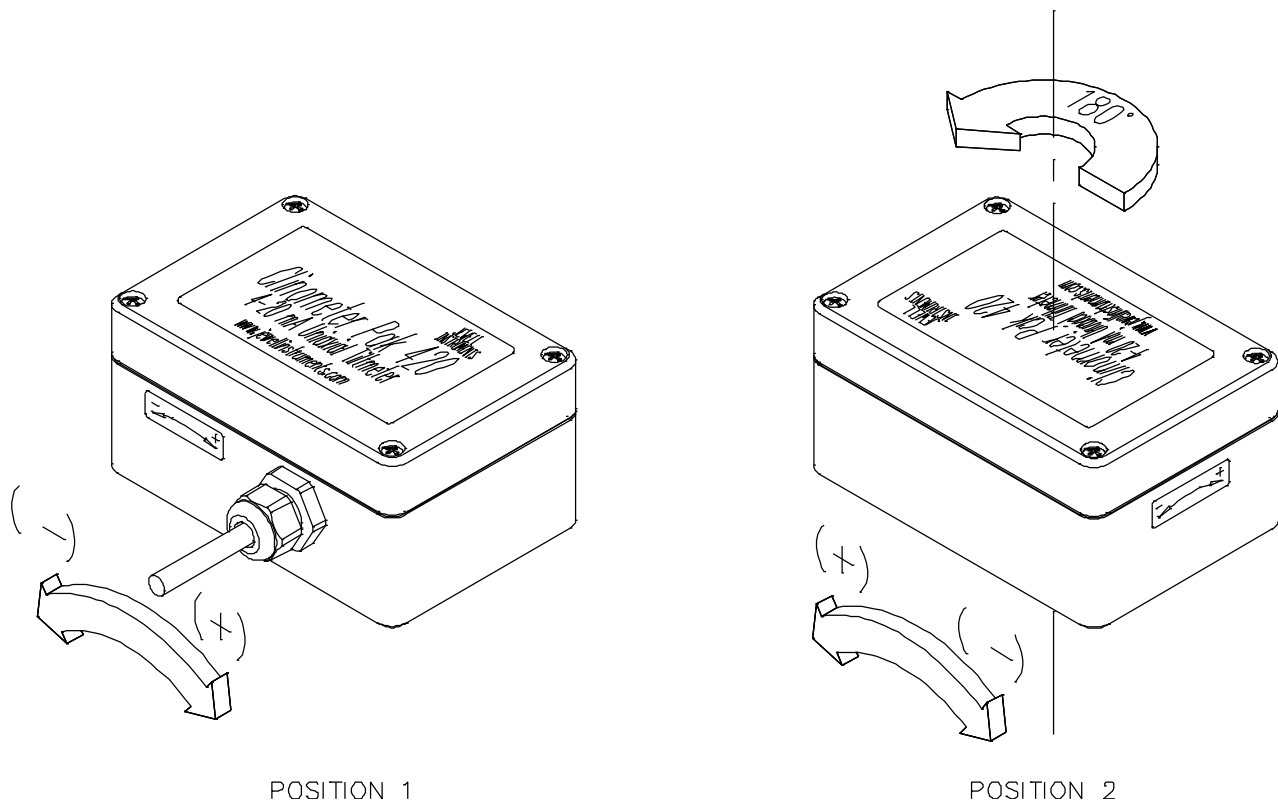

Figure 12. Measure the tilt angle in these two positions to compute the tiltmeter bias.

9 Maintenance and Troubleshooting

9.1 Routine Maintenance

The routine maintenance procedures given here will help ensure that your Clinometer 420 tiltmeter provides many years of trouble-free service.

Keep your tiltmeter clean and away from extremes of heat and cold. Dirt and extreme temperatures shorten the life of the seals and unnecessarily stress the electronic components. Keep the tiltmeter out of direct sun because solar radiation can create internal temperatures considerably greater than the ambient temperature.

The Clinometer Pak 420 is housed in a NEMA 4X rated enclosure. This means that it is protected against splashes, rainfall and hose-down conditions. However, it is not fully waterproof and should NEVER BE SUBMERGED in water or any other liquid. WATER DAMAGE TO INTERNAL COMPONENTS VOIDS THE WARRANTY!

WARNING: NEVER USE AN OHMMETER TO MEASURE ANYTHING INSIDE THE TILTMETER. APPLYING DC CURRENT THROUGH THE SENSORS WILL CAUSE PERMANENT DAMAGE THAT IS NOT COVERED BY THE WARRANTY.

9.2 Determining the Cause of Malfunctions

Apart from the procedures described below, Clinometer Pak 420 tiltmeters are not field serviceable. If you encounter problems not described here, please contact Jewell Instruments LLC at telephone (603) 669-6400, fax (603) 622-2690, or e-mail support at sales@jewellinstruments.com. A sales representative will assist you in determining the cause of any problem.

If there is no output when you have connected the tiltmeter to a recording system, first check that the ammeter or recording device has adequate power and is functioning properly. Then be sure that all connectors are securely attached. *Failure to obtain an output signal from the tiltmeter normally is the result of lack of power or a broken wire or connection.*

If the tiltmeter output is firmly “pegged” at either end of the output range, the tiltmeter is probably tilted off scale. Rotate the tiltmeter in the opposite tilt direction to check this possibility. The tiltmeter output should pass through zero volts as you move it through its null (level) position. Remember that the response is not instantaneous because of the time constant of the filter. However, no more than a few seconds should elapse before the tiltmeter responds as it moves through null.

If the tiltmeter output remains “pegged” at its positive or negative limit no matter how much you move it, the cause may be a broken connection or short circuit where the sensor lead wires connect to the printed circuit board. In this event, or if you have otherwise established that a problem is internal to the tiltmeter, contact the factory for assistance or to arrange for a repair.

10 Warranty and Assistance

Standard goods (those listed in Jewell Instruments' published sales literature, excluding software) manufactured by Jewell Instruments LLC are warranted against defects in materials and workmanship for twelve (12) months from the date of shipment from Jewell's premises with the following exceptions: Series 900 analog or digital tiltmeters are warranted against defects in materials and workmanship for 90 days from the delivery date. Jewell will repair or replace (at its option) goods that prove to be defective during the warranty period provided that they are returned prepaid to Jewell and:

- (a) that the goods were used at all times for the purpose for which they were designed and in accordance with any instructions given by Jewell in respect of them,
- (b) that notice is received by Jewell within 30 days of the defects becoming apparent, and
- (c) that return authorization is received from Jewell prior to the goods being sent back.

Should goods be damaged in transit to the Purchaser, Jewell will accept no liability unless the Purchaser can show that such damage arose solely from Jewell's failure to pack the goods properly for shipment.

Software products are warranted to perform substantially in accordance with their documentation for 90 days following your receipt of the software. Jewell and its suppliers do not and cannot warrant the performance or results you may obtain by using the software or its documentation.

In respect of goods or parts thereof manufactured by others and resold by Jewell, Jewell Instruments will pass on to the customer the benefit of any guarantee or warranty received by Jewell from the original manufacturer insofar as such guarantee or warranty is assignable.

ANY OTHER CONDITIONS OR WARRANTIES WHETHER EXPRESS OR IMPLIED BY STATUTE OR OTHERWISE ARE EXCLUDED. THE REMEDIES PROVIDED HEREIN ARE THE BUYER'S SOLE AND EXCLUSIVE REMEDIES. JEWELL INSTRUMENTS LLC SHALL NOT BE LIABLE FOR ANY DIRECT, INDIRECT, SPECIAL, INCIDENTAL OR CONSEQUENTIAL DAMAGES, INCLUDING LOST PROFITS OR LOST SAVINGS, WHETHER BASED ON CONTRACT, TORT, OR ANY OTHER LEGAL THEORY. THIS WARRANTY EXTENDS ONLY TO THE ORIGINAL PURCHASER AND IS EXPRESSLY IN LIEU OF ALL OTHER WARRANTIES, WHETHER OF MERCHANTABILITY OR FITNESS FOR ANY PARTICULAR USE, AND OF ALL OTHER OBLIGATIONS AND LIABILITIES OF ANY KIND AND CHARACTER. THERE ARE NO WARRANTIES WHICH EXTEND BEYOND THE DESCRIPTION ON THE FACE HEREOF.

- (a) Jewell's liability arising out of the sale of its goods is expressly limited to the repair and/or replacement of defective parts or the cost of such repair and/or replacement.
- (b) If software does not perform substantially in accordance with the documentation, the entire and exclusive liability and remedy shall be limited to either, at Jewell's option, the replacement of the software or the refund of the license fee you paid for the software.
- (c) Liability for any other form of loss or damage is hereby expressly excluded.
- (d) Customer shall indemnify Jewell Instruments against any third party claim arising out of the use of goods and/or services supplied by Jewell, including any claim arising directly or indirectly out of alleged negligence on the part of Jewell, its employees, servants, representatives or agents.

A How the Sense Resistor Changes the Voltage Requirement

Figure A1 shows the required minimum power supply voltage as a function of the sense resistance plus the cable resistance. Note that the cable resistance is equal to the loop wiring resistance inside the cable, which is the resistance of the wire that is twice the length of the cable. The sense resistor, R in Figure 4, is usually not present unless a data logger is used. If a sense resistor is present, it will be located at the end of the cable farthest from the tiltmeter. The sense resistor will be connected between the loop return (ground) wire of the cable and the power supply ground. The current can be measured directly using an ammeter, with no sense resistor. In this case, only the cable resistance affects the minimum power supply voltage.

**Sense Resistance Plus Cable Resistance Vs. Minimum Power Supply Voltage
Jewell Instruments 4-20 mA Tiltmeters**

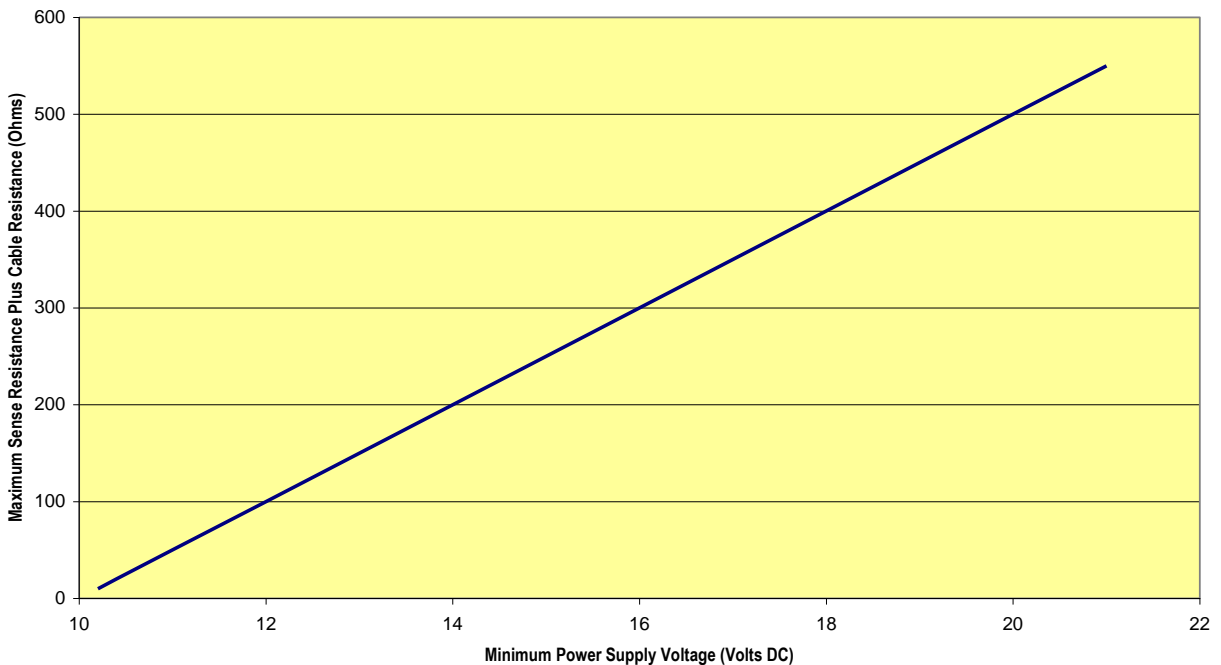

Figure 13. How the sense and cable resistance affect the minimum power supply voltage

B Custom Specifications for Your Equipment:

Serial number: _____

- Clinometer Pak 420-H/L [High-gain ($\pm 10^\circ$ range), Longitudinal configuration]
- Clinometer Pak 420-H/T [High-gain ($\pm 10^\circ$ range), Transverse configuration]
- Clinometer Pak 420-S/L [Standard ($\pm 25^\circ$ range), Longitudinal configuration]
- Clinometer Pak 420-S/T [Standard ($\pm 25^\circ$ range), Transverse configuration]
- Clinometer Pak 420-W/L [Wide-angle ($\pm 50^\circ$ range), Longitudinal configuration]
- Clinometer Pak 420-W/T [Standard ($\pm 50^\circ$ range), Transverse configuration]
- Clinometer Pak 420-S/B [Standard ($\pm 25^\circ$ range), Biaxial configuration]
- Clinometer Pak 420-H/B [High Gain ($\pm 10^\circ$ range), Biaxial configuration]
- Clinometer Pak 420-W/B [Wide-angle ($\pm 50^\circ$ range), Biaxial configuration]

Scale Factors

Scale factors are determined by linear regression with a minimum of 10 steps over the calibration range. Nonlinearity is the maximum deviation of any point from the regression line, divided by the calibration span (± 0.5 degree angular range = 1.0 degree span), expressed as percent.

Calibration Data for Your Tiltmeter					
SCALE FACTOR		μ radians/mA	arc second/mA	arc minute/mA	deg/mA
Calibration Temperature		$^\circ$ Celsius			
Max. nonlinearity	%				
Calibrated over Angular Range of	\pm	μ radians	arc second	arc minute	degrees

Temperature sensor output is measured using an ohmmeter between the blue and yellow wires in the tiltmeter cable. Temperature sensor scale is shown in the graphs in Figures 9-11. 2500 Ohms = 25°C

C Revision Table

REV.	PAGE NOS.	ECN NO.	DESCRIPTION OF CHANGE	DATE
A	ALL	26631	Release to Production	9/9/14