

MODEL EK1

TECHNICAL SPECIFICATIONS

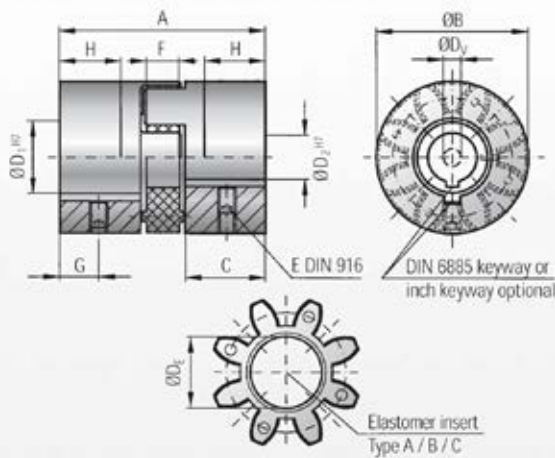

Properties:

- economically priced
- concentrically machined
- dampens vibrations
- electrical insulating
- press-fit design
- low backlash, due to keyway connection

Material:

Clamping hub: up to series 450 high strength aluminum, from series 800 and up steel
Elastomer insert: precision molded, wear resistant, and thermally stable polymer

Design:

Two coupling hubs are concentrically machined with concave driving claws
Bore tolerance H7 + keyway + set screw
DIN 916 or optional pilot bored (D_v)

*Speeds:

Over 10.000 rpm a finely balanced version is available

Tolerance:

On the hub/shaft connection 0,01 to 0,05 mm

Model EK 1	Series																										
	2			5			10			20			60			150			300			450			800		
Type (Elastomer insert)	A	B	C	A	B	C	A	B	C	A	B	C	A	B	C	A	B	C	A	B	C	A	B	C	A	B	C
Rated torque (Nm) T _{RN}	2	2.4	0.5	9	12	2	12.5	16	4	17	21	6	60	75	20	160	200	42	325	405	84	450	660	95	950	1100	240
Max. torque (Nm) T _{max}	4	4.8	1	18	24	4	25	32	6	34	42	12	120	150	35	320	400	85	650	810	170	1000	1350	190	1900	2150	400
Overall length (mm) A	20			34			35			66			78			90			114			126			162		
Outer diameter (mm) B	15			25			32			42			56			66.5			82			102			136.5		
Mounting length (mm) C	6.5			12			12			25			30			35			45			50			65		
Inner diameter pilot bored (mm) D _v	3			4			6			7			9			14			18			22			29		
Inner diameter range H7 (mm) D _{H7}	3 - 9			6 - 15			6 - 18			8 - 25			12 - 32			19 - 38			20 - 45			28 - 60			32 - 80		
Inner diameter max. (elastomer) D ₁	6.2			10.2			14.2			19.2			27.2			30.2			38.2			46.2			60.5		
Set screws (DIN 916) E	see table (depending on bore Ø)**																										
Width Elastomer insert (mm) F	5			8			9.5			12			14			15			18			20			25		
Distance (mm) G	3			5			6			9			11			12			15			17			30		
Possible shortening length (mm) H	4			6			6			19			22			26			32			37			43		
Moment of inertia (10 ⁻³ kgm ²) J ₁ /J ₂	0.0003			0.001			0.01			0.02			0.09			0.2			0.6			1.5			11.4		
Approx. weight (kg)	0.008			0.03			0.08			0.15			0.35			0.6			1.1			1.7			11		
Speed* (rpm)	28.000			22.000			20.000			19.000			14.000			11.500			9.500			8.000			4.000		

1 Nm = 8.85 in lbs

** Set screws	
D _v /D ₁	E
Ø 6-10	M3
Ø 11-12	M4
Ø 13-30	M5
Ø 31-60	M8
Ø 59-80	M10

■ Details of pilot bored coupling hubs (D_v)

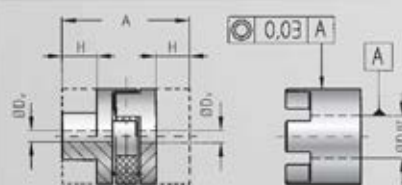

It's critical that modifications of the hub are machined concentrically and perpendicular to the through bore.

EK1 hubs can be modified to customer specifications.
The coupling hub may be shortened by measurement H.

Ordering example

EK1 / 60 / A / 19 / D_v / XX

Model	EK1
Series	60
Type Elastomer insert	A
Bore Ø D1 H7	19
Bore Ø D2 prebored	D _v
Non standard e.g. anodized	XX

All data is subject to change without notice.

Areas of application:

- Servo drives
- Machine tools
- Packaging machinery
- Plant automation
- Printing machinery
- Industrial robots
- Measurement and positioning units
- general mechanical engineering
- Linking screw jacks, linear actuators, encoders

Properties of the product range:

- vibration dampening
- electrically insulating (standard)
- backlash-free
- press-fit design
- compensation of lateral-, angular- and axial misalignment

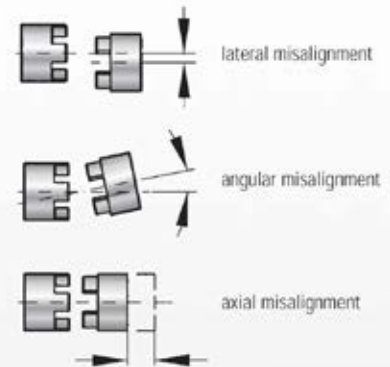

Function

The equalizing element of an EK coupling is the elastomer insert. It transmits the torque without backlash and vibration. The elastomer insert defines the features of the entire coupling and/or of the entire drive system.

The coupling is backlash free due to pretensioning of the elastomer insert between the two coupling halves. The Servomax-Coupling compensates for lateral, angular and axial misalignment.



Type A
Shore hardness 98 Sh A



Type B
Shore hardness 64 Sh D



Type C
Shore hardness 80 Sh A



Type D*
Shore hardness 92 Sh A

Specification of the Elastomer inserts

Type	Shore hardness	Color	Material	Relative damping (ψ)	Temperature range	Features
A	98 Sh A	red	TPU	0,4 - 0,5	-30°C to +100°C	high damping
B	64 Sh D	green	TPU	0,3 - 0,45	-30°C to +120°C	high torsional stiffness
C	80 Sh A	yellow	TPU	0,3 - 0,4	-30°C to +100°C	very high damping
D*	92 Sh A	black	TPU	0,3 - 0,45	-10°C to +70°C	electrically conductive*

* Due to the electrically conductive properties of the insert electrostatic load of the coupling is prevented. This eliminates sparks during normal operation (Explosive areas). Technical datas available.

The values of the relative damping were determined at 10 Hz and +20°C.

Model row EK	Series																										
	2			5			10			20			60			150			300			450			800		
Type (Elastomer insert)	A	B	C	A	B	C	A	B	C	A	B	C	A	B	C	A	B	C	A	B	C	A	B	C	A	B	C
Static torsional stiffness (Nm/rad) C_1	50	115	17	150	350	53	260	600	90	1140	2500	520	3290	9750	1400	4970	10600	1130	12400	18000	1290	15100	27000	4120	41300	66080	10320
Dynamic torsional stiffness (Nm/rad) C_{1dyn}	100	230	35	300	700	106	541	1650	224	2540	4440	876	7940	11900	1350	13400	29300	3590	23700	40400	6090	55400	81200	11600	82600	180150	28600
Lateral (mm) C_{1dyn}	0.08	0.06	0.1	0.08	0.06	0.1	0.1	0.08	0.12	0.1	0.08	0.15	0.12	0.1	0.15	0.15	0.12	0.2	0.18	0.14	0.25	0.2	0.18	0.25	0.25	0.2	0.3
Angular (degree) C_{1dyn}	1	0.8	1.2	1	0.8	1.2	1	0.8	1.2	1	0.8	1.2	1	0.8	1.2	1	0.8	1.2	1	0.8	1.2	1	0.8	1.2	1	0.8	1.2
Axial (mm) C_{1dyn}	±1			±1			±1			±2			±2			±2			±2			±2			±2		

Static torsional stiffness at 50% T_{KN}

Dynamic torsional stiffness at T_{KN}

1 Nm = 8,85 in lbs